



90 cm
ELECTRIC BUILT-IN OVEN
Model ELIO 910



Instructions for the use - Installation advices
KEEP IN A SAFE PLACE

Before operating this oven,
please read these instructions carefully

Dear Customer,

Thank you for having purchased and given your preference to our product.

The safety precautions and recommendations reported below are for your own safety and that of others. They will also provide a means by which to make full use of the features offered by your appliance.

Please preserve this booklet carefully. It may be useful in future, either to yourself or to others in the event that doubts should arise relating to its operation.

This appliance must be used only for the task it has explicitly been designed for, that is for cooking foodstuffs. Any other form of usage is to be considered as inappropriate and therefore dangerous.

The manufacturer declines all responsibility in the event of damage caused by improper, incorrect or illogical use of the appliance.

IMPORTANT SAFETY PRECAUTIONS AND RECOMMENDATIONS

IMPORTANT: This appliance is designed and manufactured solely for the cooking of domestic (household) food and is not suitable for any non domestic application and therefore should not be used in a commercial environment.

The appliance guarantee will be void if the appliance is used within a non domestic environment i.e. a semi commercial, commercial or communal environment.

Read the instructions carefully before installing and using the appliance.

- This appliance has been designed and manufactured in compliance with the applicable standards for the household cooking products and it fulfills all the safety requirements shown in this manual, including those for surface temperatures. Some people with sensitive skin may have a more pronounced temperature perception with some components although these parts are within the limits allowed by the norms. The complete safety of the appliance also depends on the correct use, we therefore recommend to always pay a extreme attention while using the product, especially in the presence of children.
- After having unpacked the appliance, check to ensure that it is not damaged and that the oven door closes correctly. In case of doubt, do not use it and consult your supplier or a professionally qualified technician.
- Packing elements (i.e. plastic bags, polystyrene foam, nails, packing straps, etc.) should not be left around within easy reach of children, as these may cause serious injuries.
- Some appliances are supplied with a protective film on steel and aluminium parts. **This film must be removed before using the appliance.**
- **IMPORTANT:** The use of suitable protective clothing/gloves is recommended when handling or cleaning this appliance.
- Do not attempt to modify the technical characteristics of the appliance as this may become dangerous to use. The manufacturer declines all responsibility for any inconvenience resulting from the inobservance of this condition.

- Do not operate your appliance by means of an external timer or separate remote-control system.
- Do not carry out cleaning or maintenance operations on the appliance without having previously disconnected it from the electric power supply.
- **WARNING:** Ensure that the appliance is switched off before replacing the oven lamp to avoid the possibility of electric shock.
- Do not use a steam cleaner because the moisture can get into the appliance therefore making it unsafe.
- Do not touch the appliance with wet or damp hands (or feet).
- Do not use the appliance whilst in bare feet.
- If you should decide not to use this appliance any longer (or decide to substitute another model), before disposing of it, it is recommended that it be made inoperative in an appropriate manner in accordance to health and environmental protection regulations, ensuring in particular that all potentially hazardous parts be made harmless, especially in relation to children who could play with unused appliances.
- The various components of the appliance are recyclable. Dispose of them in accordance with the regulations in force in your country. If the appliance is to be scrapped, remove the power cord.
- After use, ensure that the knobs are in the off position.
- Children less than 8 years of age shall be kept away unless continuously supervised.
- This appliance can be used by children aged from 8 years and above and persons with reduced physical, sensory or mental capabilities or lack of experience and knowledge if they have been given supervision or instruction concerning use of the appliance in a safe way and understand the hazards involved. Children shall not play with the appliance. Cleaning and user maintenance shall not be made by children without supervision.
- The manufacturer declines all liability for injury to persons or damage to property caused by incorrect or improper use of the appliance.

- **WARNING:** During use the appliance and its accessible parts become hot; they remain hot for some time after use.
 - Care should be taken to avoid touching heating elements inside the oven.
 - The door is hot, use the handle.
 - To avoid burns and scalds, young children should be kept away.
- Make sure that electrical cables connecting other appliances in the proximity of the oven cannot become entrapped in the oven door.
- **WARNING:** When correctly installed, your product meets all safety requirements laid down for this type of product category. However special care should be taken around the rear or the underneath of the appliance as these areas are not designed or intended to be touched and may contain sharp or rough edges, that may cause injury.
- **FIRST USE OF THE OVEN** - it is advised to follow these instructions:
 - Furnish the interior of the oven as described in the chapter “CLEANING AND MAINTENANCE”.
 - Switch on the empty oven on max to eliminate grease from the heating elements.
 - Disconnect the appliance from the electrical power supply, let the oven cool down and clean the interior of the oven with a cloth soaked in water and neutral detergent; then dry carefully.
- **CAUTION:** Do not use harsh abrasive cleaners or sharp metal scrapers to clean the oven door glass since they can scratch the surface, which may result in shattering of the glass.
- Do not line the oven walls or floor with aluminium foil. Do not place baking trays or the drip tray on the base of the oven chamber.
- **FIRE RISK!** Do not store flammable material in the oven.
- Always use oven gloves when removing the shelves and food trays from the oven whilst hot.
- Do not hang towels, dishcloths or other items on the appliance or its handle – as this could be a fire hazard.

- Clean the oven regularly and do not allow fat or oils to build up in the oven base or tray. Remove spillages as soon as they occur.
- Do not stand on the open oven door.
- Always stand back from the appliance when opening the oven door to allow steam and hot air to escape before removing the food.
- **SAFE FOOD HANDLING:** Leave food in the oven for as short a time as possible before and after cooking. This is to avoid contamination by organisms which may cause food poisoning. Take particular care during warmer weather.
- **WARNING:** Take care NOT to lift the appliance by the door handle.
- The appliance must not be installed behind a decorative door in order to avoid overheating.
- The oven accessories (e.g. oven wire rack) must be fitted correctly as indicated at page 43.
- **IMPORTANT NOTE:** The oven shelves (for some products one shelf only is provided) have not been designed to place the food directly on the shelf itself. When cooking, always place the food in special containers or use specific materials suitable for the food contact.
- If the power supply cable is damaged, it must be replaced only by an authorized service agent in order to avoid a hazard.
- If the appliance is not fitted with a supply cord and a plug, or with other means for disconnection from the supply mains having a contact separation in all poles that provide full disconnection under overvoltage category III conditions, means for disconnection must be incorporated in the fixed wiring in accordance with the wiring rules. ***NOT APPLICABLE IN SINGAPORE MARKET**
- **WARNING:** The appliance and its accessible parts become hot during use.
Care should be taken to avoid touching heating elements.
Children less than 8 years of age shall be kept away unless continuously supervised.

ADVICE
for the
INSTALLER

1 INSTALLATION

IMPORTANT

- The appliance is designed and approved for domestic use only and should not be installed in a commercial, semi commercial or communal environment. Your product will not be guaranteed if installed in any of the above environments and could affect any third party or public liability insurances you may have.
- Appliance installation and maintenance must only be carried out by QUALIFIED TECHNICIANS and in compliance with the local safety standards. Failure to observe this rule will invalidate the warranty.
- Always disconnect the appliance from the electrical power supply before carrying out any maintenance operations or repairs.
- The walls surrounding the oven must be made of heat-resistant material.
- Take care NOT to lift the oven by the door handle.
- Under no circumstances should any external covers be removed for servicing or maintenance except by suitably qualified personnel.
- **Appliance will be directly wired to the mains by fixed wiring in accordance to the Code of Practice for electrical installations SS 638 by a qualified electrician and will not be connected to the mains 3-pin mains plug. The size of the fixed wiring used will also comply with the required Safety Standards as stated in the IEC 60335-1.**

WARNING

When correctly installed, your product meets all safety requirements laid down for this type of product category.

However special care should be taken around the rear or the underneath of the appliance as these areas are not designed or intended to be touched and may contain sharp or rough edges, that may cause injury.

IMPORTANT

- The oven can be fitted in standard units, width 90 cm and depth 60 cm.
- Installation requires a compartment as illustrated in figures 1.1a and 1.1b. On the lower side, the oven must lay on supports standing the oven weight.
- Remember the housing should not be free standing but be secured to the wall and/or adjacent fittings.

WARNING

- We would point out that the adhesive which bonds the plastic laminate to the furniture must withstand temperatures not less than 150°C to avoid delamination.
- The appliance must be housed in heat resistant units.
- **The walls of the units must be capable of resisting temperatures of 70°C above room temperature.**

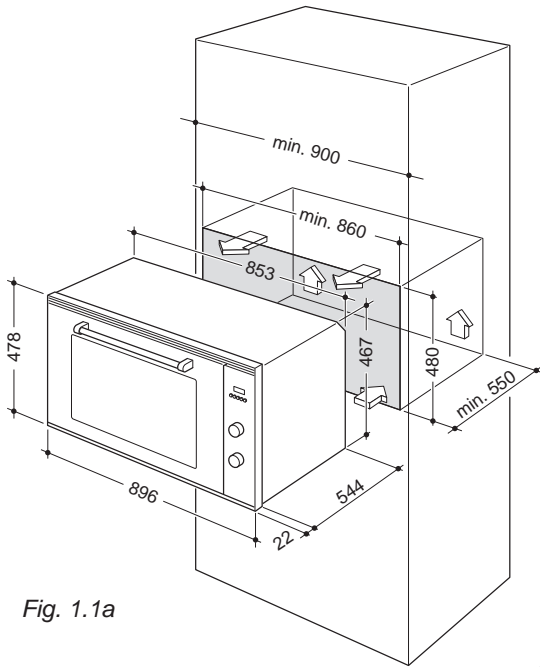

Fig. 1.1a

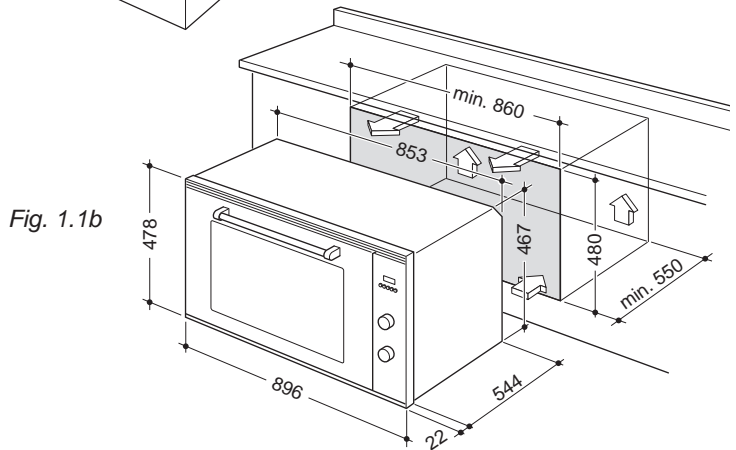

Fig. 1.1b

WARNING, VERY IMPORTANT:

The oven is supplied with no.6 rubber spacers fixed at the bottom.

DO NOT install the oven without these spacers correctly in place.

If one or more rubber spacers are missing, please use the ones contained in the separate kit supplied with this appliance and fix them to the bottom of the oven as indicated in the figure 1.2a on the next page.

Should you require assistance please contact our Customer Service Centre .

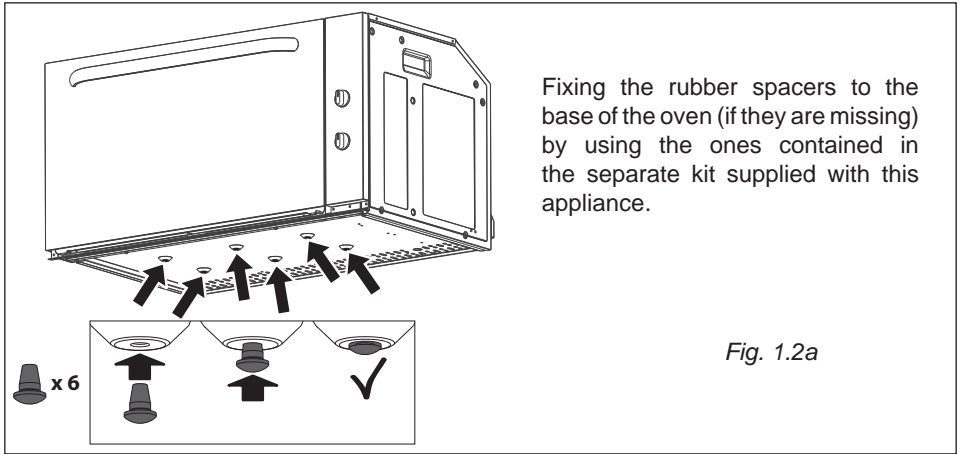

FIXING THE OVEN

Introduce the oven into the furniture opening and fix it with 4 screws (not supplied) as figure 1.2b. It is essential that the oven rests on a surface which will support its weight, as the screw fixing is only complementary.

Adjust the hinges of furniture doors adjacent to the oven to allow a 4-5 mm gap between the furniture door and the oven frame.

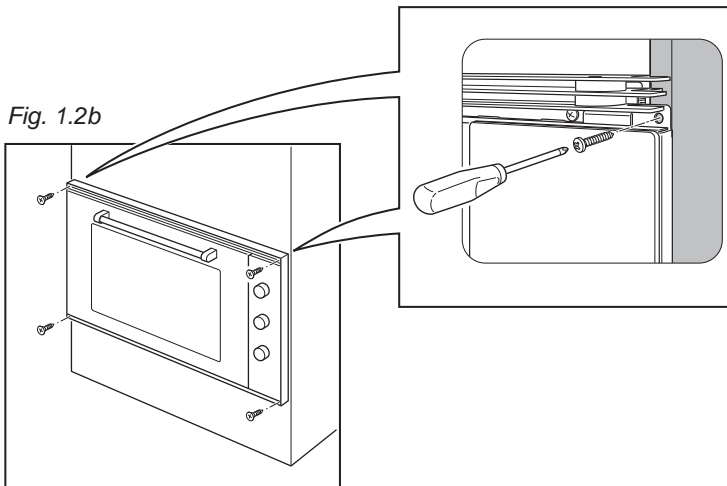

IMPORTANT:

To avoid damage to the lower trim please note the following instructions.

The lower trim is designed to allow for good air circulation and the correct opening of the oven door.

To ensure the trim is not damaged due to the appliance being placed on the floor, the appliance should be suitably supported as in illustration here below.

After installation the appliance door should be slowly opened to ensure no damage has occurred.

No responsibility for lower trim damage will be accepted if these instructions have not been followed.

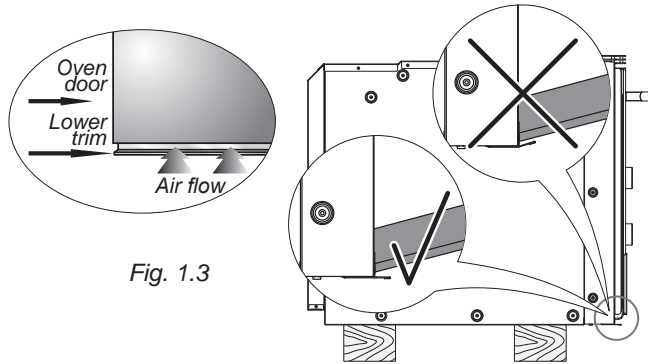

Fig. 1.3

IMPORTANT: (SOME MODELS ONLY)

When handling the oven, take care not to damage the door sensor lever "L" (near the top right corner of the oven seal).

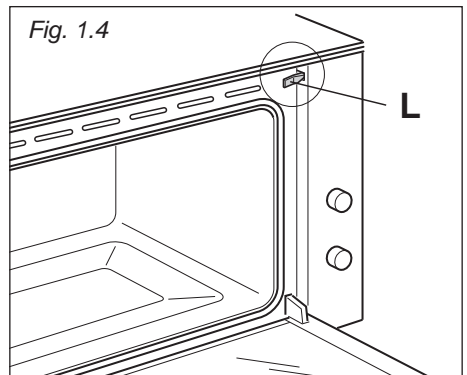

Fig. 1.4

IMPORTANT: The appliance must be installed by a qualified technician according with the current local regulations and in compliance with the manufacturer instructions. Incorrect installation might cause harm and damage to people, animals or objects, for which the manufacturer accepts no responsibility.

Before effecting any intervention on the electrical parts of the appliance, the connection to the network must be interrupted.

GENERAL

- Connection to the mains must be carried out by qualified personnel in accordance with current regulations.
- The appliance must be connected to the mains checking that the voltage corresponds to the value given in the rating plate and that the electrical cable sections can withstand the load specified on the plate.
- If the appliance is supplied without a power supply plug and if you are not connecting directly to the mains, a standardized plug suitable for the load must be fitted. *NOT APPLICABLE IN SINGAPORE MARKET
- The appliance can be connected directly to the mains placing an omnipolar switch with minimum opening between the contacts of 3 mm between the appliance and the mains.
- The power supply cable must not touch the hot parts and must be positioned so that it does not exceed 50°C at any point.
- Once the appliance has been installed, the switch or socket must always be accessible.
- If the power supply cable is damaged it must be substituted by a suitable cable available in the after sales service.

N.B. For connection to the mains, do not use adapters, reducers or branching devices as they can cause overheating and burning.

If the installation requires alterations to the domestic electrical system or if the socket and appliance plug are incompatible, call an expert. *NOT APPLICABLE IN SINGAPORE MARKET

He should also check that the socket cable section is suitable for the power absorbed by the appliance.

The connection of the appliance to earth is mandatory.

The manufacturer declines all responsibility for any inconvenience resulting from the inobservance of this condition.

CONNECTION OF THE POWER SUPPLY CABLE

WARNING: If the power supply cable is damaged, it must be replaced only by an authorised service agent in order to avoid a hazard.

- Unhook the terminal board cover by inserting a screwdriver into the two hooks “A” (fig. 2.1).
- Unscrew the screw “D” and open completely the cable clamp “E” (fig. 2.2).
- Connect the phase, neutral and earth wires to terminal board “G” according to the diagram in fig. 2.3.
- Strain the feeder cable and block it with cable clamp “E” (by screwing screw “D”).
- Close the terminal block cover (check the two hooks “A” are correctly hooked).

IMPORTANT: To connect the power supply cable **DO NOT** unscrew the screws fixing the cover plate behind the terminal block.

NOTE: The earth conductor must be left about 3 cm longer than the others.

The operations must be executed by a qualified technician.

FEEDER CABLE SECTION

Type “H05RR-F”

220-240 Vac 3 x 1,5 mm² (*) (**)

(*) Connection possible with plug and outlet *NOT APPLICABLE IN SINGAPORE MARKET.

(**) Connection with wall box connection.

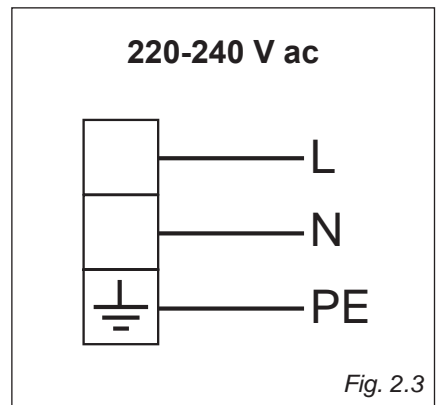
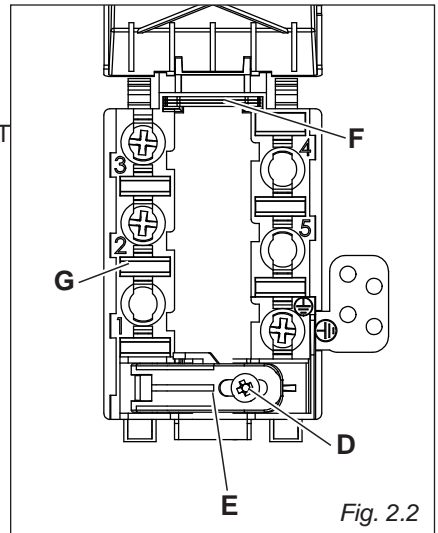
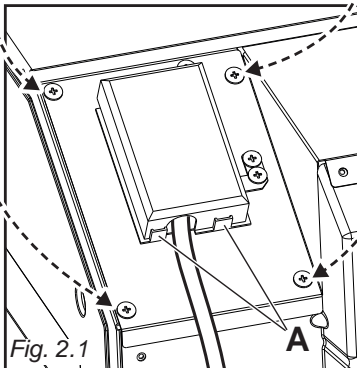
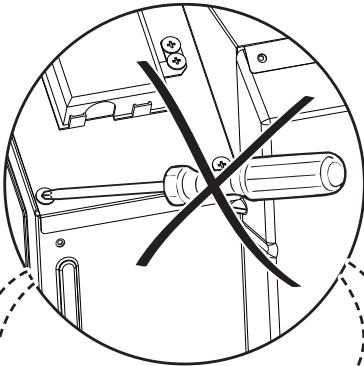

ADVICE
for the
USERS

USING THE PRESS-AND-TURN CONTROL KNOBS (SOME MODELS ONLY)

The control knobs are flush-mounted in the control panel.

Use them as follows:

- Press lightly on the knob (figure A);
- The knob will extend outwards as illustrated in figure B.
- Turn the knob to the required position (figure C).
- When you have finished cooking, turn the knob back to the “0”, “O” or “□” (off) position and press it (figure D) so that it stays flush with the control panel again (figure F).

IMPORTANT:

Never press down the knob when it is not in the “0”, “O” or “□” (off) position (figure 1.8E).

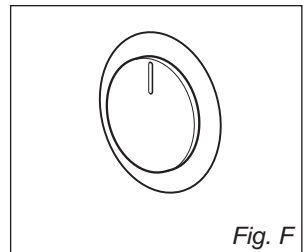
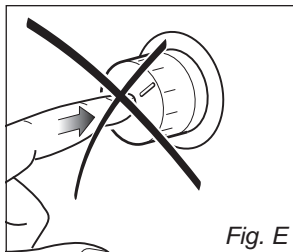
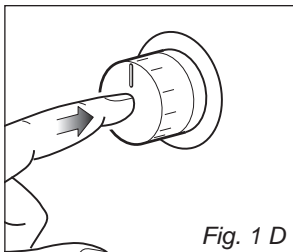
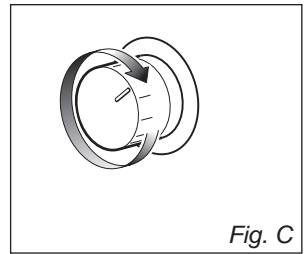
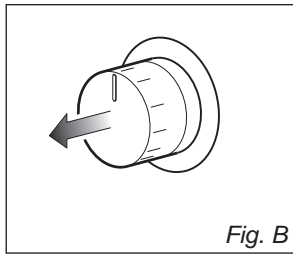
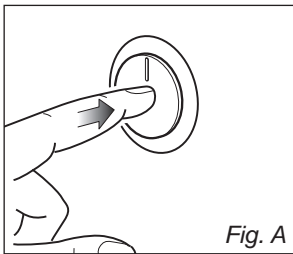

1 CONTROL PANEL

Fig. 1.1

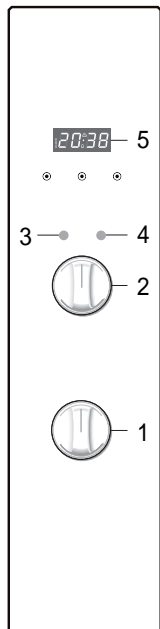

Fig. 1.2

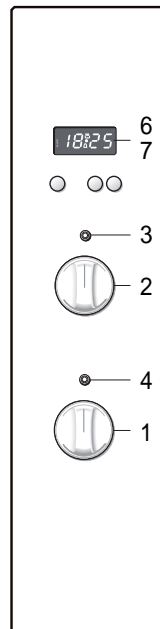

Fig. 1.3

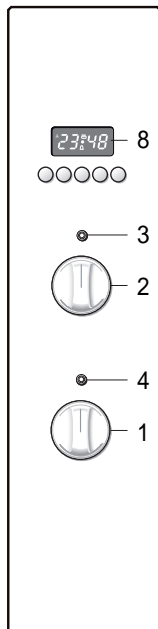
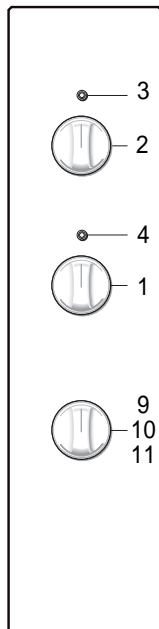

Fig. 1.4



CONTROLS DESCRIPTION

1. Oven thermostat knob
2. Function selector knob
3. Power on indicator lamp
4. Oven temperature indicator lamp
5. Clock and timer with "Touch-Control" keys
6. Electronic clock
7. Electronic clock/end cooking timer
8. Electronic programmer
9. 60' alarm
10. 120' alarm
11. Timer (120' cut-off)

Please note:

Your appliance has been fitted with a cooling fan to achieve optimum efficiency of the controls and to ensure lower surface temperatures are maintained.

The cooling fan motor switches ON/OFF depending on temperature.

Depending on cooking temperatures and times, the cooling fan may run on even after the appliance oven has been switched off.

The duration of this time is dependent on previous cooking temperature and duration.

2

OVEN VERSIONS

NATURAL CONVECTION MODELS

TYPE 1

Fig. 2.1a

Function selector knob

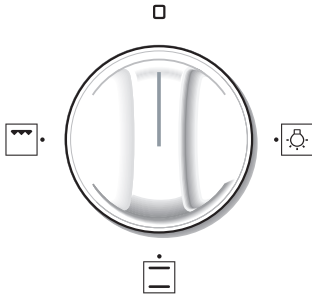

NOTES: The knob and symbols may vary. The symbols may be printed on the knob itself.

TYPE 2

Fig. 2.1b

Function selector knob

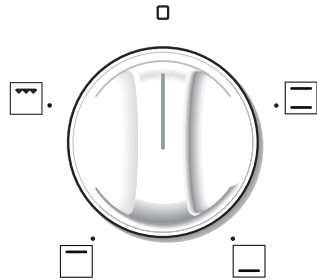

NOTES: The knob and symbols may vary. The symbols may be printed on the knob itself.

GENERAL FEATURES

This oven features no.2 (fig. 2.1a) or no.4 (fig. 2.1b) different thermostatic control functions to satisfy all cooking requirements, provided by 3 heating elements:

The input of the elements is:

- Upper element;
- Lower element;
- Grill element.

NOTE:

Upon first use, it is advisable to operate the oven at the maximum temperature for 60 minutes in the position  to eliminate possible traces of grease on the heating elements.

Repeat the operation for another 15 minutes with the grill element on as explained in the chapters "TRADITIONAL GRILLING" and "USE OF THE GRILL".

OPERATING PRINCIPLES

Heating and cooking in the natural convection oven are obtained in the following ways:

- by normal convection**
The heat is produced by the upper and lower heating elements.
- by radiation**
The heat is radiated by the infrared grill element.

NATURAL CONVECTION WITH ROTISSERIE MODELS

TYPE 1

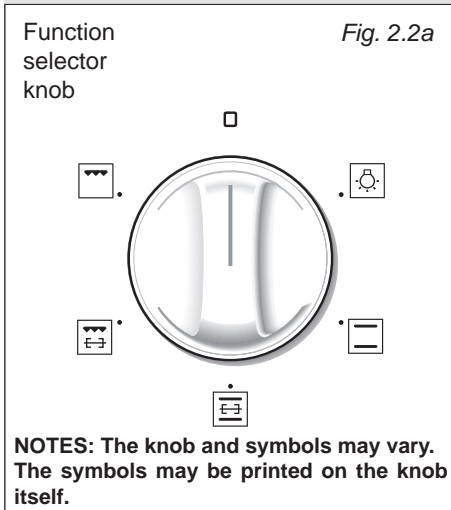

TYPE 2

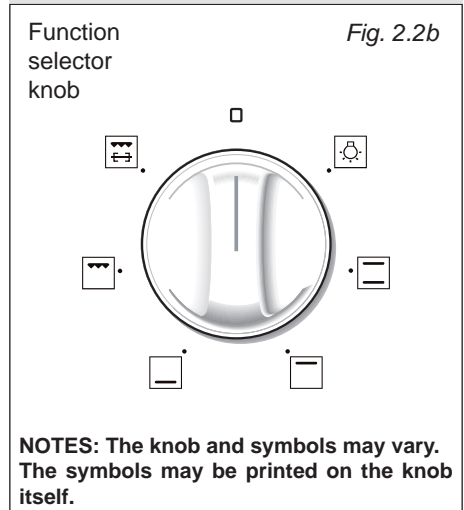



GENERAL FEATURES

This oven features no.4 (fig. 2.2a) or no.5 (fig. 2.2b) different thermostatic control functions to satisfy all cooking requirements, provided by 3 heating elements:

The input of the elements is:

- Upper element;
- Lower element;
- Grill element.

NOTE:

Upon first use, it is advisable to operate the oven at the maximum temperature for 60 minutes in the position  (fig. 2.2a) or  (fig. 2.2b) to eliminate possible traces of grease on the heating elements.

Repeat the operation for another 15 minutes with the grill element on as explained in the chapters “TRADITIONAL GRILLING” and “USE OF THE GRILL”.

OPERATING PRINCIPLES

Heating and cooking in the natural convection oven are obtained in the following ways:

- by normal convection**
The heat is produced by the upper and lower heating elements.
- by radiation**
The heat is radiated by the infrared grill element.

FAN WITH GRILL MODELS

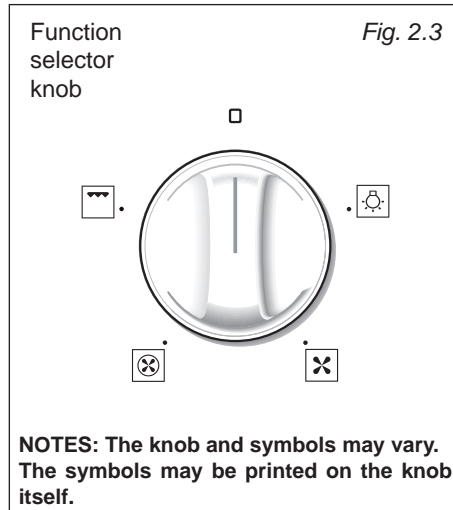

GENERAL FEATURES

The heating and cooking in electrical hot air ovens take place by forced convection.

The two elements which make this process take place are:

- Grill element;
- Circular element.

NOTE:

Upon first use, it is advisable to operate the oven at the maximum temperature for 60 minutes in the position  to eliminate possible traces of grease on the heating elements.

Repeat the operation for another 15 minutes with the grill element on as explained in the chapters "TRADITIONAL GRILLING" and "USE OF THE GRILL".

OPERATING PRINCIPLES

Heating and cooking in the fan oven are obtained in the following ways:

- by forced convection**
A fan sucks in the air contained in the oven, which circulates it through the circular heating element and then forced back into the oven by the fan. Before the hot air is sucked back again by the fan to repeat the described cycle, it envelops the food in the oven, provoking a complete and rapid cooking. It is possible to cook several dishes simultaneously.
- by radiation**
The heat is radiated by the infrared grill element.
- by ventilation**
The food is defrosted by using the fan only function without heat.

TYPE 1

Fig. 2.4a

Function selector knob

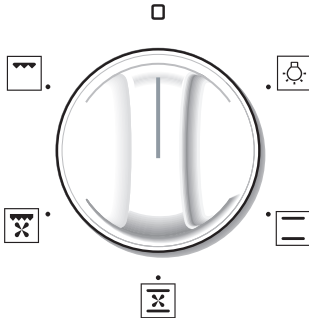

NOTES: The knob and symbols may vary. The symbols may be printed on the knob itself.

TYPE 2

Fig. 2.4b

Function selector knob

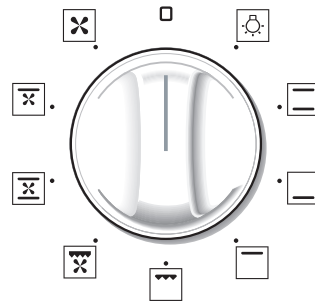

NOTES: The knob and symbols may vary. The symbols may be printed on the knob itself.

GENERAL FEATURES

As its name indicates, this is an oven that presents particular features from an operational point of view.

In fact, it is possible to insert no.4 (fig. 2.4) different programs to satisfy every cooking need.

The 4 positions, thermostatically controlled, are obtained by 3 heating elements which are:

- Upper element;
- Lower element;
- Grill element.

NOTE:

Upon first use, it is advisable to operate the oven at the maximum temperature for 60 minutes in the position  to eliminate possible traces of grease on the heating elements.

Repeat the operation for another 15 minutes with the grill element on as explained in the chapters "TRADITIONAL GRILLING" and "USE OF THE GRILL".

OPERATING PRINCIPLES

Heating and cooking in the plurifunction oven are obtained in the following ways:

- a. **by normal convection**
The heat is produced by the upper and lower heating elements.
- b. **by semi-forced convection**
The heat produced by the upper and lower heating elements is distributed throughout the oven by the fan.
fig. 2.4b: In the  function the heat is produced by the top heating element only.
- c. **by radiation**
The heat is radiated by the infra-red grill element.
- d. **by radiation and ventilation**
The radiated heat from the infra-red grill element is distributed throughout the oven by the fan.
- e. **by ventilation**
The food is defrosted by using the fan only function without heat.

PLURIFUNCTION WITH ROTISSERIE MODELS

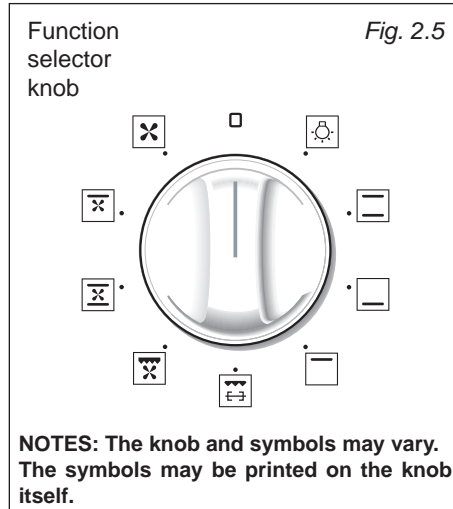

GENERAL FEATURES

As its name indicates, this is an oven that presents particular features from an operational point of view.

In fact, it is possible to insert no.8 (fig. 2.5) different programs to satisfy every cooking need.

The 8 positions, thermostatically controlled, are obtained by 3 heating elements which are:

- Upper element;
- Lower element;
- Grill element.

NOTE:

Upon first use, it is advisable to operate the oven at the maximum temperature for 60 minutes in the position  to eliminate possible traces of grease on the heating elements.

Repeat the operation for another 15 minutes with the grill element on as explained in the chapters "TRADITIONAL GRILLING" and "USE OF THE GRILL".

OPERATING PRINCIPLES

Heating and cooking in the plurifunction oven are obtained in the following ways:

- by normal convection**
The heat is produced by the upper and lower heating elements.
- by semi-forced convection**
The heat produced by the upper and lower heating elements is distributed throughout the oven by the fan.
In the  function the heat is produced by the top heating element only.
- by radiation**
The heat is radiated by the infra-red grill element.
- by radiation and ventilation**
The radiated heat from the infra-red grill element is distributed throughout the oven by the fan.
- by ventilation**
The food is defrosted by using the fan only function without heat.

MULTIFUNCTION MODELS

TYPE 1

Function selector knob

Fig. 2.6a

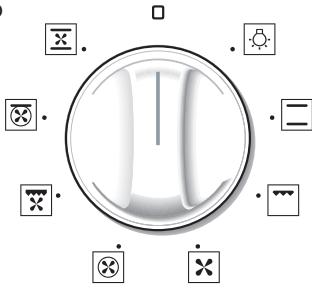

NOTES: The knob and symbols may vary.
The symbols may be printed on the knob itself.

TYPE 2

Function selector knob

Fig. 2.6b

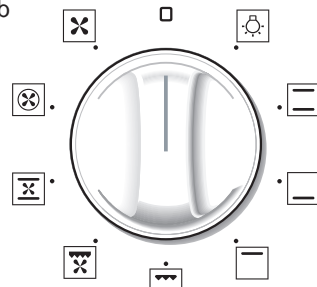

NOTES: The knob and symbols may vary.
The symbols may be printed on the knob itself.

GENERAL FEATURES



As its name indicates, this is an oven that presents particular features from an operational point of view.

In fact, it is possible to insert no.7 (fig. 2.6a) or no.8 (fig. 2.6b) different programs to satisfy every cooking need.

The 7 or 8 positions, thermostatically controlled, are obtained by 4 heating elements which are:

- Upper element;
- Lower element;
- Grill element;
- Circular element.

NOTE:

Upon first use, it is advisable to operate the oven at the maximum temperature for 60 minutes in the position  and  to eliminate possible traces of grease on the heating elements.

Repeat the operation for another 15 minutes with the grill element on as explained in the chapters "TRADITIONAL GRILLING" and "USE OF THE GRILL".

OPERATING PRINCIPLES

Heating and cooking in the multifunction oven are obtained in the following ways:

- a. **by normal convection**
The heat is produced by the upper and lower heating elements.
- b. **by semi-forced convection**
A fan sucks in the air contained in the oven, which circulates it through the circular heating element and then forced back into the oven by the fan. Before the hot air is sucked back again by the fan to repeat the described cycle, it envelops the food in the oven, provoking a complete and rapid cooking. It is possible to cook several dishes simultaneously.
- c. **by semi-forced convection**
The heat produced by the upper and lower heating elements is distributed throughout the oven by the fan.
In the  function the heat is produced by the top heating element only.
- d. **by radiation**
The heat is radiated by the infra red grill element.
- e. **by radiation and ventilation**
The radiated heat from the infra red grill element is distributed throughout the oven by the fan.
- f. **by ventilation**
The food is defrosted by using the fan only function without heat.

MULTIFUNCTION WITH ROTISSERIE MODELS

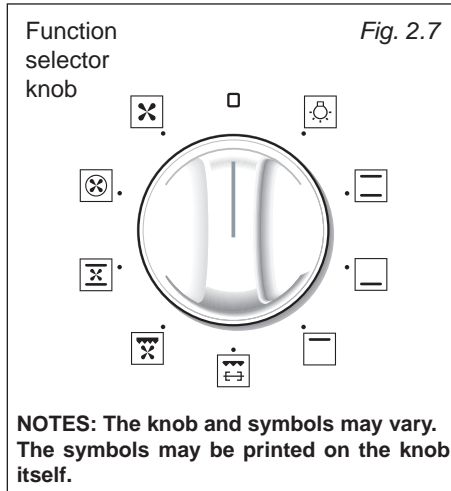

GENERAL FEATURES



As its name indicates, this is an oven that presents particular features from an operational point of view.

In fact, it is possible to insert no.8 (fig. 2.7) different programs to satisfy every cooking need.

The 8 positions, thermostatically controlled, are obtained by 4 heating elements which are:

- Upper element;
- Lower element;
- Grill element;
- Circular element.

NOTE:

Upon first use, it is advisable to operate the oven at the maximum temperature for 60 minutes in the position  and  to eliminate possible traces of grease on the heating elements.

Repeat the operation for another 15 minutes with the grill element on as explained in the chapters "TRADITIONAL GRILLING" and "USE OF THE GRILL".

OPERATING PRINCIPLES

Heating and cooking in the multifunction oven are obtained in the following ways:

- by normal convection**
The heat is produced by the upper and lower heating elements.
- by semi-forced convection**
A fan sucks in the air contained in the oven, which circulates it through the circular heating element and then forced back into the oven by the fan. Before the hot air is sucked back again by the fan to repeat the described cycle, it envelops the food in the oven, provoking a complete and rapid cooking. It is possible to cook several dishes simultaneously.
- by semi-forced convection**
The heat produced by the upper and lower heating elements is distributed throughout the oven by the fan.
- by radiation**
The heat is radiated by the infra red grill element.
- by radiation and ventilation**
The radiated heat from the infra red grill element is distributed throughout the oven by the fan.
- by ventilation**
The food is defrosted by using the fan only function without heat.

3

HOW TO USE THE OVEN

ATTENTION:

The oven door becomes very hot during operation.
Keep children away.

WARNING:

The door is hot, use the handle.

WARNING:

During use the appliance becomes hot. Care should be taken to avoid touching heating elements inside the oven.

THERMOSTAT CONTROL KNOB

(fig. 3.1)

To turn on the heating elements of the oven, set function selector knob to the required position and the thermostat knob to the desired temperature.

The elements will turn on or off automatically which is determined by the thermostat. The operation of the heating elements is signalled by a light placed on the control panel.

FUNCTION SELECTOR CONTROL KNOB

(fig. 2.1a, 2.1b, ..., 2.7)

Rotate the knob clockwise to set the oven to one of the following functions:

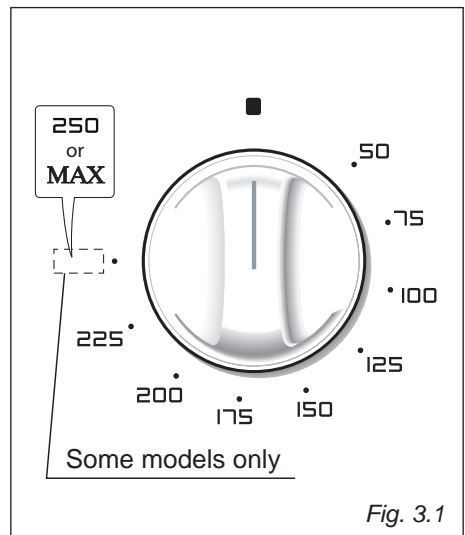

Oven functions												
Natural convection models Type 1	✓	(-)	✓	✓	✓	✓	✓	✓	✓	✓	✓	✓
Natural convection models Type 2	✓	✓	✓	✓	✓	✓	✓	✓	✓	✓	✓	✓
Natural convection with rotisserie models Type 1	✓	✓	✓	✓	✓	✓	✓	✓	✓	✓	✓	✓
Natural convection with rotisserie models Type 2	✓	✓	✓	✓	✓	✓	✓	✓	✓	✓	✓	✓
Fan with grill models	✓											
Plurifunction models Type 1	✓						✓	✓	✓	✓	✓	✓
Plurifunction models Type 2	✓						✓	✓	✓	✓	✓	✓
Plurifunction with rotisserie models	✓						✓	✓	✓	✓	✓	✓
Multifunction models Type 1	✓						✓	✓	✓	✓	✓	✓
Multifunction models Type 2	✓						✓	✓	✓	✓	✓	✓
Multifunction with rotisserie models	✓						✓	✓	✓	✓	✓	✓

(1) The oven light/s operate/s on all selected functions.

(2) Function  without using the rotisserie.

(3) Function  with thermostat knob set to “0”, “●” or “■” (off).

NOTE: DEPENDING ON YOUR MODEL, YOUR OVEN MAY ONLY HAVE SOME OF THESE FUNCTIONS (SEE CHAPTER 2 AND TABLE AT PAGE NO. 26).



OVEN LIGHT

By turning the function selector knob to this setting, the oven lights will illuminate in the oven cavity.

The oven lights will operate on all selected functions.

Natural convection type 2 models only:

The oven lights operates on all selected functions.



TRADITIONAL CONVECTION COOKING

The upper and lower heating elements are switched on.

The heat is diffused by natural convection and the temperature must be regulated between 50°C and the maximum position with the thermostat knob.

It is necessary to preheat the oven before introducing the foods to be cooked.

Some models only: In the position  the rotisserie motor come on for cooking with the rotisserie.

Recommended for:

For foods which require the same cooking temperature both internally and externally, i. e. roasts, spare ribs, meringue, etc.



LOWER HEATING ELEMENT

In this position only the lower heating element is switched on.

Heat is distributed by natural convection.

The temperature must be regulated between 50°C and **200°C maximum** with the thermostat knob.

Recommended for:

To complete cooking of dishes that require higher temperature at the bottom.



UPPER HEATING ELEMENT

In this position only the upper heating element is switched on.

Heat is distributed by natural convection.

The temperature must be regulated between 50°C and the maximum position with the thermostat knob.

Recommended for:

To complete cooking of dishes that require higher temperature at the top.



TRADITIONAL GRILLING

The infrared heating element is switched on. The heat is diffused by radiation.

Use with the oven door closed and the temperature must be regulated between 50°C and **200°C maximum** with the thermostat knob.

It is necessary to preheat the oven for about 5 minutes.

For correct use see chapter "USE OF THE GRILL".

Some models only: In the  position the rotisserie motor come on for cooking with the rotisserie. For correct use see chapters "USE OF THE GRILL" and "USE OF THE ROTISSERIE".

Recommended for:

Intense grilling action for cooking with the broiler; browning, crisping, "au gratin", toasting, etc.



VENTILATED GRILL COOKING

The infrared heating element and the fan motor are switched on.

The heat is mainly diffused by radiation and the fan then distributes it throughout the oven.

Use with the oven door closed and the temperature must be regulated between 50°C and **200°C maximum** with the thermostat knob.

It is necessary to preheat the oven for about 5 minutes.

For correct use see chapter "GRILLING AND AU GRATIN".

Recommended for:

For grill cooking when a fast outside browning is necessary to keep the juices in, i. e. veal steak, steak, hamburger, etc.



CONVECTION COOKING WITH VENTILATION

The upper and lower heating elements and the fan motor are switched on.

The heat coming from the top and bottom is diffused by forced convection.

The temperature must be regulated between 50 °C and the maximum position with the thermostat knob.

Recommended for:

For foods of large volume and quantity which require the same internal and external degree of cooking; for ex: rolled roasts, turkey, legs, cakes, etc.



UPPER HEATING ELEMENT WITH VENTILATION

The upper heating element and the fan motor are switched on.

The heat coming from the top is diffused by forced convection.

The temperature must be regulated between 50°C and 150°C with the thermostat knob.

Recommended for:

To keep foods hot after cooking.
To slowly heat already cooked foods.



HOT AIR COOKING

The circular heating element and the fan motor are switched on.

The heat is diffused by forced convection and the temperature must be regulated between 50°C and the maximum position with the thermostat knob.

It is not necessary to preheat the oven.

Recommended for:

For foods that must be well done on the outside and tender or rare on the inside, i. e. lasagna, lamb, roast beef, whole fish, etc.



DEFROSTING FROZEN FOODS

Only the oven fan is switched on.

To be used with the thermostat knob in the "0", "●" or "■" (off) position because the other positions have no effect.

The defrosting is done by simple ventilation without heat.

Plurifunction models only: Set the function selector knob to . With the thermostat knob in the "0", "●" or "■" (off) position only the oven fan is switched on.

Recommended for:

To rapidly defrost frozen foods; 1 kilogram requires about one hour.

The defrosting times vary according to the quantity and type of foods to be defrosted.



MAINTAINING TEMPERATURE AFTER COOKING OR SLOWLY HEATING FOODS

The upper and circular heating elements connected in series and the fan motor are switched on. The heat is diffused by forced convection with the most part being produced by the upper element. The temperature must be regulated between 50°C and 140°C with the thermostat knob.

Recommended for:



To keep foods hot after cooking.
To slowly heat already cooked foods.

COOKING ADVICE

NOTE: DEPENDING ON YOUR MODEL, YOUR OVEN MAY ONLY HAVE SOME OF THESE FUNCTIONS (SEE CHAPTER 2 AND TABLE AT PAGE NO. 26).



STERILIZATION

Sterilization of foods to be conserved, in full and hermetically sealed jars, is done in the following way:

- Set the switch to position  or .
- Set the thermostat knob to position 185°C and preheat the oven.
- Fill the grill pan with hot water.
- Set the jars into the grill pan making sure they do not touch each other and the door and set the thermostat knob to position 135°C.

When sterilization has begun, that is, when the contents of the jars start to bubble, turn off the oven and let cool.

COOKING DIFFERENT DISHES AT THE SAME TIME

With the function selector in position  or , the ventilated oven allows you to cook different types of food at the same time.

Fish, cakes and meat can be cooked together without the smells and flavours mixing.

The only precautions required are the following:

- The cooking temperatures must be as close as possible with a maximum difference of 20 - 25°C between the different foods.
- Different dishes must be placed in the oven at different times according to the cooking time required for each one. This type of cooking obviously provides a considerable saving on time and energy.

REGENERATION

Set the switch to position  and the thermostat knob to position 150°C.

Bread becomes fragrant again if wet with a few drops of water and put into the oven for about 10 minutes.

ROASTING

To obtain classical roasting, it is necessary to remember:

- that it is advisable to maintain a temperature between 180 and 200°C.
- that the cooking time depends on the quantity and the type of foods.

USE OF THE GRILL

Leave to warm up for approximately 5 minutes with the door **closed**.

Place the food inside positioning the rack as near as possible to the grill.

Insert the drip pan under the rack to collect the cooking juices.

GRILLING AND “AU GRATIN”

Grilling may be done by selecting grill+fan setting  with the function selector knob, because the hot air completely envelops the food that is to be cooked.

Set the thermostat knob and after having preheated the oven, simply place the food on the grid.

Close the door and let the oven operate until grilling is done.

Adding a few dabs of butter before the end of the cooking time gives the golden “au gratin” effect.

Always grill with the oven door closed.

It is recommended that you do not grill for longer than 60 minutes at anyone time.

Attention: The oven door becomes very hot during operation.

Keep children away.

The external parts of the oven become hot during operation.

Keep children well out of reach.

USING THE ROTISSERIE (MODELS WITH ROTISSERIE ONLY)

1. Prepare the rotisserie support (fig. 3.2).

- Place the grill tray on the benchtop.
- Insert the supports into the lock studs.
- Push the supports all the way down to lock them in firmly.

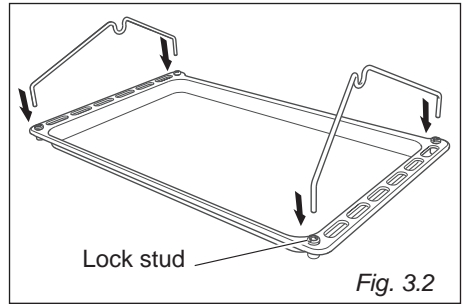

Fig. 3.2

2. Secure the meat (fig. 3.3).

Important!

Take care, the forks are sharp!

When securing the meat, ensure that:

- the skewer goes through the centre of the meat;
- the forks hold the meat firmly in place;
- the fork screws are tightened;
- there are no loose or projecting parts. Poultry should be trussed.

Note: the rotisserie can rotate up to 6 kg of meat.

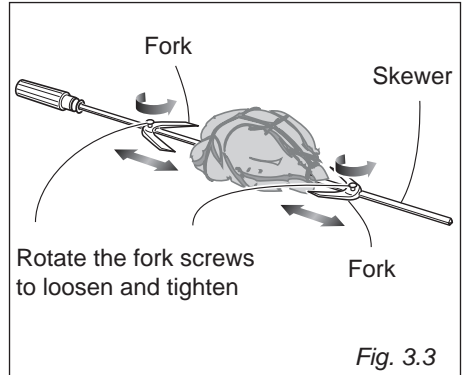

Fig. 3.3

3. Position the skewer on the support (fig. 3.4).

- Place the skewer on the support, and check that the meat does not touch the grill tray.
- Twist the handle off. It must not be left in the oven.

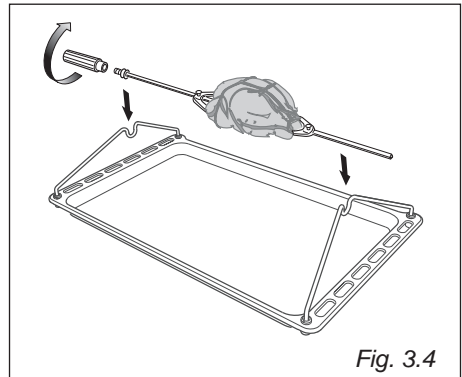

Fig. 3.4

4. Place the rotisserie assembly in the oven (fig. 3.5).

- Slide the grill tray all the way to the back on shelf position.

IMPORTANT NOTE: DO NOT place the grill tray on the sliding shelf supports (if fitted).

- Push the skewer through the hole cover on the right-hand wall of the oven, then insert it fully into the rotisserie drive hole.

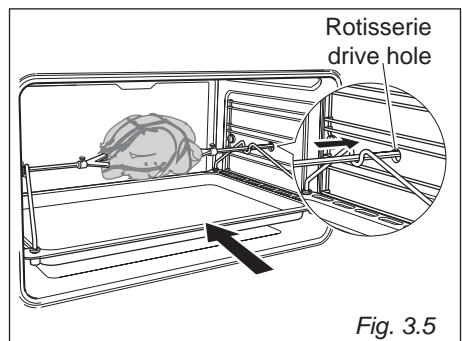



Fig. 3.5

5. Start the rotisserie

- Check that the fat filter is in place.
- Select the  function.
- Set the temperature.

4

CLOCK and TIMER with "TOUCH CONTROL" KEYS

Keys:		
A and C	⊕ and ⊖ or ⬆ and ⬇ or other equivalent symbols	Touched simultaneously (for more than 2 seconds): <ul style="list-style-type: none"> • setting the clock; • setting the timer volume (by touching once, along with the "B" key); • to cancel automatic cooking at any time.
B	MODE or other equivalent wording / symbol	Function selection (touched for more than 2 seconds): <ul style="list-style-type: none"> • setting the clock (only after first connection or after a power failure); • timer; • automatic cooking "dur" (duration) - how long the food will take to cook (by touching the "B" key again); • automatic cooking "End" - the time you would like the oven turns off (by touching the "B" key two more times).
A	⊖ or ⬇ or other equivalent symbols	Decreases the number shown on the display
C	⊕ or ⬆ or other equivalent symbols	Increases the number shown on the display

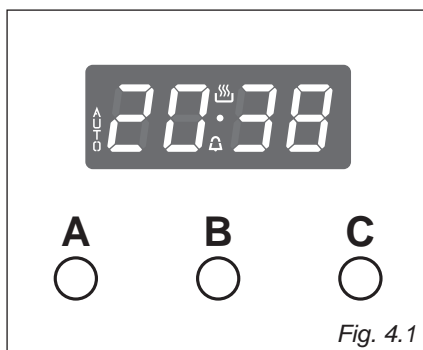

Fig. 4.1

Illuminated symbols:		
AUTO	flashing	Automatic cooking completed, oven in automatic position but not set
AUTO	steady illumination	Oven set for automatic cooking, cooking still not taking place
	flashing	Timer being set
	steady illumination	Timer in operation
	steady illumination	Oven set for manual cooking
and AUTO	AUTO flashing	Automatic cooking being set
and AUTO	steady illumination	Oven set for automatic cooking, cooking taking place

“TOUCH-CONTROL” KEYS

The “touch-control” keys shall be operated by the fingers (just by touching the key). When using touch controls it is best to use the ball of your finger rather than the tip.

The keys are automatically deactivated:

- 8 seconds after the last selection; the deactivation is indicated by an acoustic signal (“beep”).

To reactivate just touch the “B” key or the “A” and “C” keys (simultaneously) for more than 2 seconds.

SETTING THE CLOCK

When first connected, or after a power failure, the digits and “AUTO” will shown on the display.

Important: The oven does not operate, in manual cooking, without first having set the clock.

To set the clock, touch the “B” key, for more than 2 seconds, and then the “A” or “C” keys. To set the clock, with the appliance already connected, touch the “A” and “C” keys simultaneously (for more than 2 seconds), then “A” or “C” keys.

Important:



- changing the time will delete any automatic program;
- after setting the clock, the oven starts to operate in the selected function (manual cooking). The “” symbol is steady illuminated.

USING THE TIMER

You can use the timer at any time, even when the oven is not in use.

The timer does not turn the oven off.

The timer can be set for up to 23 hours and 59 minutes.

- To set the timer, touch the “B” key for more than 2 seconds (the “” symbol flashes), than the “C” or “A” keys.
- After about 8 seconds an acoustic signal (“beep”) will sound confirming the regulation (“” symbol steady illuminated).
- To check the remaining time touch the “B” key for more than 2 seconds. If the remaining time is more than a minute the display will show hours and minutes; if less than a minute the display will show seconds.
- When the time is up, the timer will beep. Touch the “B” key , for more then 2 seconds, to turn it off; or press the “A” or “C” key to stop the beep and than the “B” key, for more than 2 seconds, to deactivate the “” symbol flashing on the display.
- Turn off the oven manually (function and thermostat knobs in the off position) if the manual cooking has been completed.

SETTING THE TIMER VOLUME

You can select from three volume levels.

- Touch the “**A**” and “**C**” keys simultaneously for more than 2 seconds.
- Touch the “**B**” key; you can read on the display the current timer volume (“**ton1**”, “**ton2**” or “**ton3**”).
- Touch the “**A**” key to listen or change the timer volume.
- Timer volume activated: the last displayed.
- After about 8 seconds an acoustic signal (“**beep**”) will sound confirming the volume setting; then the time of day will be displayed.

AUTOMATIC COOKING

Use automatic cooking to automatically turn the oven on, cook, and then turn the oven off.

1. Check the clock shows the correct time.
2. Select the function and temperature (function and temperature knobs). The oven will come on.
3. Decide how long the food will take to cook, allowing time for preheating if necessary.
4. Touch the “**B**” key for more than 2 seconds and then touch again; “**dur**” will show (duration). Using the “**C**” and “**A**” keys, set the cooking time.
5. Decide the time you would like the oven to turn off; touch the “**B**” key for more than 2 seconds and then touch it two times again; “**End**” will show. Using the “**C**” and “**A**” keys, set the stop time.

Note: while “**dur**” is displayed you can change to “**End**” just by touching one time the “**B**” key (within 8 seconds from the last selection).

If there is time to wait before cooking starts, the current time of day and “**AUTO**” will show in the clock display. The oven will switch off but is now set for automatic cooking.

If you are already at home to turn the oven on and only want the oven to turn off automatically, start cooking as normal, then follow step 4 or step 5 to set a time to stop the oven.

When automatic cooking starts, “” will be displayed and the oven will turn on.

- To see the remaining cook time, follow step 4 up to display “**dur**” (duration).
- To see the set stop time, follow step 5 up to display “**End**”.
- To cancel automatic cooking at any time, touch the “**A**” and “**C**” keys simultaneously (for more than 2 seconds) and turn the temperature and function knobs to the off position.

When the stop time is reached, the oven will turn off, the timer will beep and “**AUTO**” will flash:

- Touch any key to stop the beeping.
- Touch the “**B**” key, for more than 2 seconds, to return the oven to the manual mode (“” symbol steady illuminated on the display).
- Turn the temperature and function knobs to the off position.





Attention: After a power failure any automatic program is deleted. Turn off the oven manually.

5

ELECTRONIC PROGRAMMER

The electronic programmer is a device which groups together the following functions:

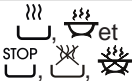
- 24 hours clock with illuminated display
- Timer (up to 23 hours and 59 minutes)
- Program for automatic oven cooking
- Program for semi-automatic oven cooking

Description of the buttons:		
A	 or other equivalent symbols	Timer
B	 or other equivalent symbols	Cooking time
C	 or other equivalent symbols	End of cooking time
	 or other equivalent symbols	Simultaneously: Switching to manual and program reset.
D	 or other equivalent symbols	To decrease the numbers on the digital display
E	 or other equivalent symbols	To increase the numbers on the digital display

Caution: If the electricity supply is cut off (the display numbers will flash), the clock will reset and all the programs entered will be cancelled.

Description of the illuminated symbols:

A flashing - Programmer in automatic position but not programmed

A illuminated - Programmer in automatic position with program inserted.

 Automatic cooking taking place

 Timer in operation

 and **A** - flashing - Program error.
(The time of day lies between the calculated cooking start and end time).

Note:

Select a function by the respective button and, in 5 seconds, set the required time with the "D" / "E" buttons ("one-hand" operation).

After a power cut the display resets to zero and cancels the set programs.

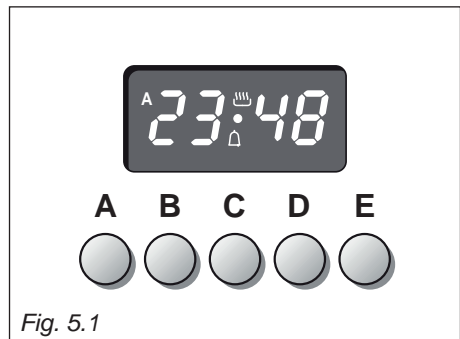

Fig. 5.1

SETTING TIME OF DAY (fig. 5.2)

The programmer is provided with an electronic clock with luminous figures showing the hour and minutes.

The first time the oven is connected up to the electricity supply and after a power cut, three zeroes will flash on the programmer display.

To adjust the time, the two buttons "B" "C" must be pressed simultaneously and then the button "D" or "E" until the correct time is set.

Setting speed automatically increases if you keep the setting buttons pressed.

MANUAL OPERATION

To use the oven manually, i.e. without the programmer, you must cancel the flashing **A** by pressing the two buttons "B" "C" simultaneously (the letter **A** will go out and the symbol  will come on).

CANCELLING A PROGRAMME

If the letter **A** is not flashing (which means that a cooking program has already been set) by pressing the two buttons "B" "C" simultaneously you will cancel the program and switch to manual.

If the oven is on, you must switch it off manually.

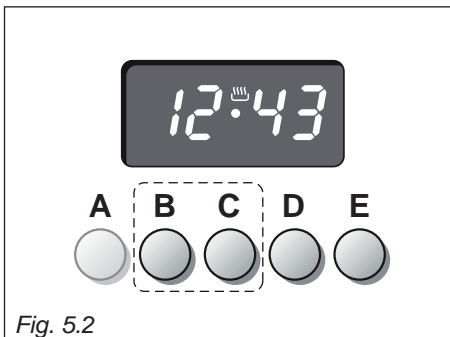

Fig. 5.2

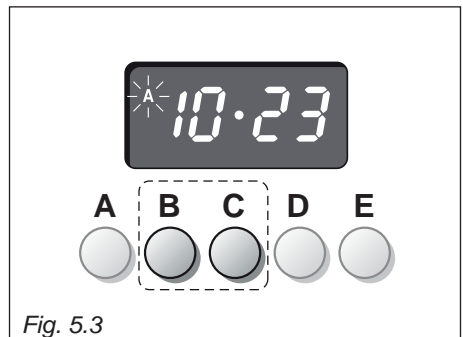

Fig. 5.3

MINUTE MINDER

The minute counter function consists simply of an acoustic signal which can be set for a maximum of 23 hours 59 minutes.

If the letter **A** is flashing, press the two buttons "**B**" "**C**" simultaneously.

To set the time, press button "**A**" and then button "**D**" or "**E**" until the required time appears on the display (fig. 5.4).

The symbol  will come on.

Countdown will begin immediately and can be seen on the display at any time by simply pressing button "**A**".

When the time expires, the symbol  will go out and an intermittent acoustic signal will come on which can be switched off by pressing any of the buttons.

AUDIBLE SIGNAL

The audible signal sounds at the end of a minute minder cycle or of a cooking programme for a period of 7 minute.

The signal can be cancelled by pressing any function button.

Pressing the "**D**" button without having previously selected a function the frequency of the signal change. You can choose from three variations.

The selected signal is audible as long as the button "**D**" is pressed.

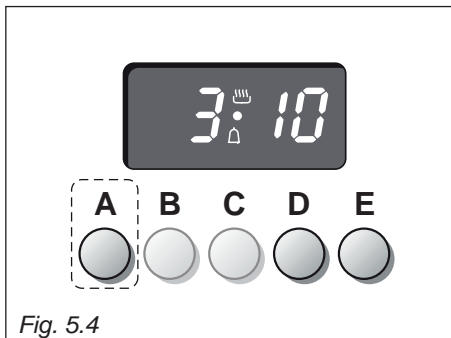

Fig. 5.4

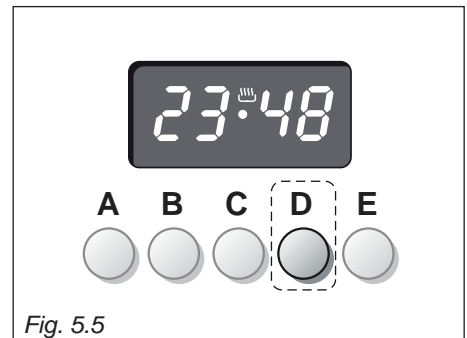



Fig. 5.5

SEMI - AUTOMATIC COOKING

This automatically switches the oven off after the required cooking time. There are two methods of semi-automatic cooking:

1° METHOD: Programming the cooking time (fig. 5.6)

- Set the cooking time by pressing button "B" and then button "E" to move forward or "D" to move back if you have gone beyond the required time.

The letter **A** and the symbol  will appear.

2° METHOD: Programming the end of cooking time (fig. 5.7)

- Set the end of cooking time by pressing button "C" and then button "E" to move forward or "D" to move back if you have gone beyond the required time.

The letter **A** and the symbol  will appear.

Having programmed according to one of the above methods, set the temperature and function via the function selector and thermostat knob (see specific chapters).

The oven will come on immediately and when the set time or programmed end of cooking time expires, it will automatically switch off.

During cooking the letter **A** and the symbol  remains on; press button "B" to display the remaining time until end of cooking or press button "B" to display the end of cooking time.

The cooking program can be cancelled at any time by pressing the two buttons "B" "C" simultaneously.

At the end of cooking, turn the oven knob to the off position the  symbol will go out. The letter **A** will flash and the acoustic signal will come on - this can be switched off by pressing any of the buttons.

Reset the function selector and thermostat knob and set the programmer to manual by pressing the two buttons "B" "C" simultaneously.

Important: Also if oven is turned off automatically by the programmer, remember to turn to the off position the function selector and the thermostat knob. If not, when pressing two buttons "B" "C" simultaneously for manual use, the oven will start to operate.

Remember to press the two buttons "B" "C" simultaneously to be able to use the oven in manual setting.

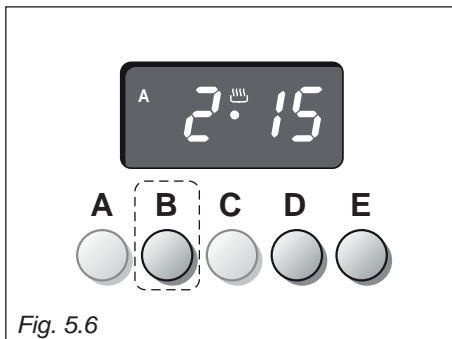

Fig. 5.6

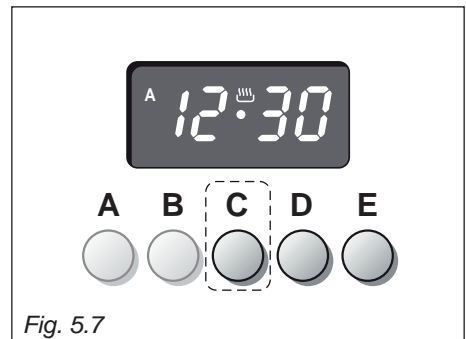

Fig. 5.7

AUTOMATIC COOKING

To cook in the oven in automatic mode follow the instructions below:

1. Set the cooking time
2. Set the end of cooking time
3. Set the cooking temperature and function

These operations are carried out as follows:

1. Set the cooking time by pressing button "B" and then "E" to move forward or "D" to move back if you have gone beyond the required time (fig. 5.8).

The letter **A** and the symbol  appear.

2. Press button "C" ; the cooking time already added to the clock time appear.

Set the end of cooking time by pressing button "E" if you go beyond the required time, you can go back by pressing button "D".

The symbol  go out and the letter **A** remains on (fig. 5.9).

If during the setting the letter **A** begins to flash on the display and the acoustic signal comes on, this indicates a programming error, i.e. the cooking cycle has been superimposed on the clock time. In this case alter the end of cooking time or the cooking time as above.

3. Set the cooking temperature and function via the function selector and thermostat knob (see specific chapters).

The oven is now programmed and everything will work automatically; the oven will come on as required and finish cooking at the programmed time.

At the start of the cooking the symbol  appear.

During cooking the letter **A** and the symbol  remains on; press button "B" to display the remaining time until end of cooking or press button "B" to display the end of cooking time.

The cooking program can be cancelled at any time by pressing the two buttons "B" "C" simultaneously.

At the end of cooking, the oven switch off, the symbol  go out, the letter **A** flash and the acoustic signal come on - this can be switched off by pressing any of the buttons.

Reset the function selector and thermostat knob and set the programmer to manual by pressing the two buttons "B" "C" simultaneously.

Important: Also if oven is turned off automatically by the programmer, remember to turn to the off position the function selector and the thermostat knob. If not, when pressing two buttons "B" "C" simultaneously for manual use, the oven will start to operate.

Remember to press the two buttons "B" "C" simultaneously to be able to use the oven in manual setting.

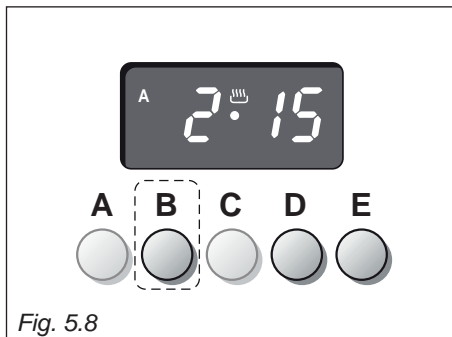

Fig. 5.8

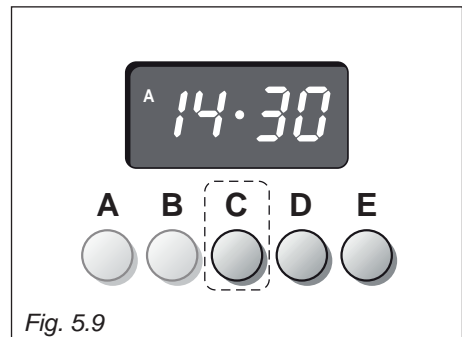

Fig. 5.9



6

ELECTRONIC CLOCK/END COOKING TIMER

MODELS WITH ELECTRONIC CLOCK/END COOKING TIMER (fig. 6.1)

The electronic clock/end cooking timer is a device which groups the following functions:

- 24 hours clock with illuminated display;
- timing of oven cooking with automatic switch-off (max 99 minutes).

Description of the buttons:		
A	 or other equivalent symbols	Timer
B	 or other equivalent symbols	To decrease the numbers on the digital display
C	 or other equivalent symbols	To increase the numbers on the digital display

ELECTRONIC CLOCK

Upon immediate connection of the cooker or after a mains failure, three zeros will flash on the display.

To set the clock it is necessary to push the "A" button and then, within 7 seconds, the "B" or "C" button until you have set the correct time.

The clock will show zero after a mains failure.

Attention: When the display shows three zeros the oven cannot be switched on.

The oven can be switched on when the symbol  is shown in the display.

SETTING THE FREQUENCY OF THE ALARM SOUND

The selection from 3 possibilities of sound can be made by pressing the "B" button.

COOKING WITH AUTOMATIC SWITCH-OFF

The aim of this function is to automatically stop the cooking after a preprogrammed time, for a maximum period of 99 minutes.

To set the cooking time, push the "B" or "C" button until you obtain the desired time in the display. The symbol **AUTO** (or **A**) will be shown

in the display. Then set the oven selector and thermostat knobs according to the cooking function and temperature required.

The oven will immediately start to operate and will work for the preprogrammed time. The display shows the count down.

Clock time can be displayed by pressing the "A" button. Once the time has elapsed, the oven will switch off automatically, the symbol **AUTO** (or **A**) will go off and an intermittent buzzer, lasting 7 minutes, will start; this can be stopped by pressing the "C" button.

Important: Before the buzzer is stopped switch off the oven manually.

To cancel the cooking program at any time press the "B" and "C" buttons together and release the "C" button first.

ELECTRONIC ALARM

The electronic clock can be used as an alarm only for a maximum period of 99 minutes.

To set the alarm, push the "B" or "C" button until you obtain the desired time in the display. Once the time has elapsed, an intermittent buzzer, lasting 7 minutes, will start; this can be stopped by pressing the "C" button.

Attention: If the oven is switched on when the buzzer starts, it will be automatically switched off. For it to operate furtherly you have to stop the buzzer by pressing the "C" button.

Then remember to switch the oven off manually.

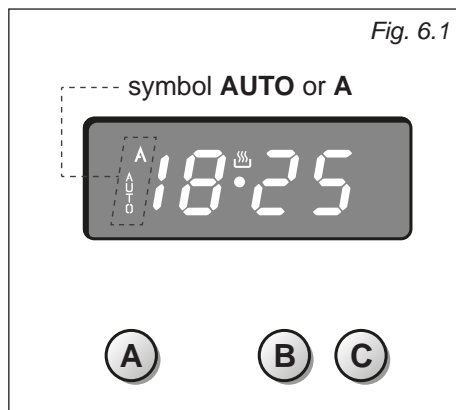

7

ELECTRONIC CLOCK WITH ALARM

MODELS WITH ELECTRONIC CLOCK WITH ALARM (fig. 7.1)



The electronic clock is a device which groups the following functions:

- 24 hours clock with illuminated display;
- 99 minutes alarm.

Upon immediate connection of the oven or after a blackout, three zeros will flash on the display.

To set the hour it is necessary to push the "A" button and then, within 7 seconds, the "B" or "C" button until you have set the exact hour.

An energy black-out makes the clock go to zero.

Description of the buttons:		
A	 or other equivalent symbols	Timer
B	 or other equivalent symbols	To decrease the numbers on the digital display
C	 or other equivalent symbols	To increase the numbers on the digital display

ELECTRONIC ALARM

The alarm program consists only of a buzzer which may be set for a maximum period of 99 minutes.

To set the time, push the "B" or "C" button until you obtain the desired time in the display.

Having finished the setting, the  symbol will be lit and the countdown will start immediately.

At the end of the time, an intermittent buzzer, during 7 minutes, will go off; this can be stopped by pressing the "C" button.

To stop the alarm countdown in any moment press the "B" and "C", buttons together and release the "C" button first.

SETTING THE FREQUENCY OF THE ALARM SOUND

The selection from 3 possibilities of sound can be made by pressing the "B" button.

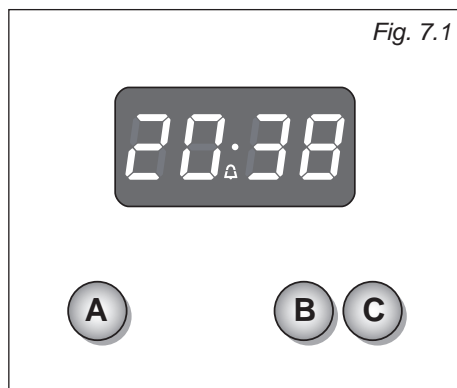

8

60' or 120' ALARM – 120' CUT-OFF TIMER

NOTES: The knob and symbols may vary. The symbols may be printed on the knob itself.

MODELS WITH 60 MINUTES ALARM (fig. 8.1)

The minute counter is a timed acoustic warning device which can be set for a maximum of 60 minutes.

The knob must be rotated clockwise as far as the 60 minute position and then set to the required time by rotating it anticlockwise.

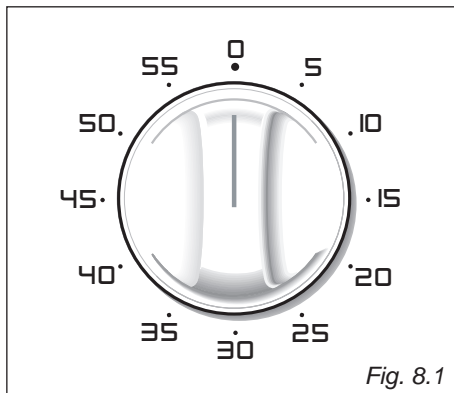

Fig. 8.1

MODELS WITH 120 MINUTES ALARM (fig. 8.2)

The minute counter is a timed acoustic warning device which can be set for a maximum of 120 minutes.

The knob must be rotated clockwise as far as the 120 minute position and then set to the required time by rotating it anticlockwise.

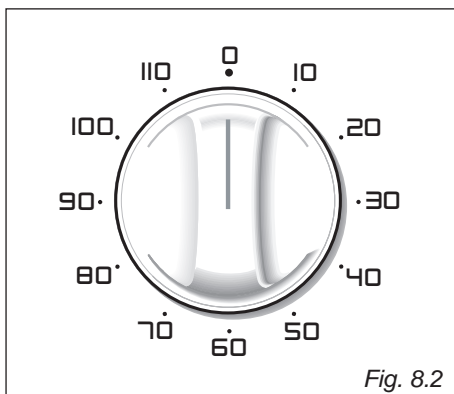

Fig. 8.2

MODELS WITH 120 MINUTES CUT-OFF TIMER (fig. 8.3)

The function of the timer runs the oven for a preset time.

1) Starting up.

After setting the function selector and thermostat to the required mode and temperature, rotate the timer knob clockwise until you reach the required cooking time (max 120 minutes).

Once this time has elapsed, the timer will return to the "0", "O" or "□" (off) position and the oven will automatically switch off.

2) Manual position.

If the cooking time is longer than two hours or if you wish to use the oven manually, switching it off as required, the knob must be turned to position .

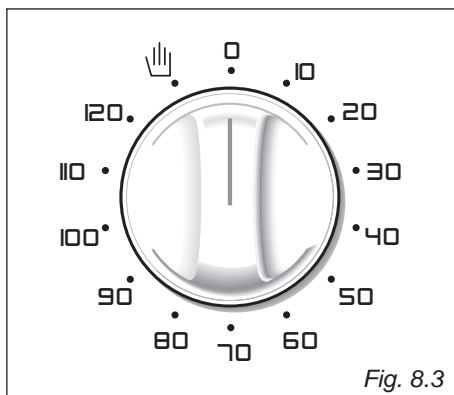

Fig. 8.3

9

CLEANING AND MAINTENANCE

GENERAL ADVICE

- **Important: Before any operation of cleaning and maintenance disconnect the appliance from the electrical supply.**
- It is advisable to clean when the appliance is cold and especially when cleaning the enamelled parts.
- Avoid leaving alkaline or acidic substances (lemon juice, vinegar, etc.) on the surfaces.
- Avoid using cleaning products with a chlorine or acidic base.
- **Important: The use of suitable protective clothing/gloves is recommended when handling or cleaning of this appliance.**
- Clean surfaces with a damp cloth and use gentle, neutral cleaning products. Dry with a clean, dry cloth.
- **IMPORTANT:** Do not use any abrasive products (e.g. certain types of sponge) and/or aggressive products (e.g. caustic soda, products containing corrosive substances), which could cause irreparable surface damage.

WARNING

When correctly installed, your product meets all safety requirements laid down for this type of product category.

However special care should be taken around the rear or the underneath of the appliance as these areas are not designed or intended to be touched and may contain sharp or rough edges, that may cause injury.

ENAMELLED PARTS

All the enamelled parts must be cleaned with a sponge and soapy water or other non-abrasive products.

Dry preferably with a microfibre or soft cloth.

Acidic substances like lemon juice, tomato sauce, vinegar etc. can damage the enamel if left too long.

STAINLESS STEEL, ALUMINIUM PARTS AND PAINTED OR SILK-SCREEN PRINTED SURFACES

Clean using an appropriate product. Always dry thoroughly.

IMPORTANT: These parts must be cleaned very carefully to avoid scratching and abrasion. You are advised to use a soft cloth and neutral soap.

CAUTION: Do not use abrasive substances or non-neutral detergents as these will irreparably damage the surface.

GLASS CONTROL PANEL (SOME MODELS ONLY)

Clean using an appropriate product. Always dry thoroughly.

Do not use harsh abrasive cleaners or sharp metal scrapers to clean the control panel since they can scratch the surface, which may result in shattering of the glass.

Important: The manufacturer declines all liability for possible damage caused by the use of unsuitable products to clean the appliance.



Do not store flammable material in the oven.

Do not use a steam cleaner because the moisture can get into the appliance thus make it unsafe.

Do not use harsh abrasive cleaners or sharp metal scrapers to clean the oven door glass since they can scratch the surface, which may result in shattering of the glass.

INSIDE OF OVEN

The oven should always be cleaned after use when it has cooled down.

The cavity should be cleaned using a mild detergent solution and warm water.

Suitable proprietary chemical cleaners may be used after first consulting with the manufacturers recommendations and testing a small sample of the oven cavity.

Abrasive cleaning agents or scouring pads/cloths should not be used on the cavity surface.

NOTE: The manufacturers of this appliance will accept no responsibility for damage caused by chemical or abrasive cleaning.

Let the oven cool down and pay special attention no to touch the hot heating elements inside the oven cavity.

OVEN FITTING OUT

1. MODELS WITH EMBOSSED CAVITY

The oven shelf is provided with a security block to prevent accidental extraction. It must be inserted operating as per figure 9.1. To remove it, operate in the reverse order.

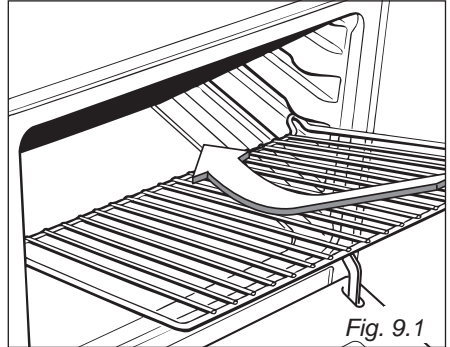

Fig. 9.1

2. MODELS WITH SIDE WIRE RACKS

- Assemble the wire racks to the oven walls using the 2 screws (fig. 9.2b).

In the models with catalytic panels supplied, interpose the catalytic panels "A" with the arrow up (fig. 9.2a). **Models with rotisserie:** The catalytic panel with the hole for the rotisserie must be positioned on the right oven wall. **DO NOT INTERPOSE THE CATALYTIC PANEL WITHOUT THE HOLE ON THE RIGHT OVEN WALL.**

- Slide the rack into the runners (fig. 9.2a). The rack must be fitted so that the safety notch, which stops it sliding out, faces the inside of the oven; the guard rail shall be at the back.
- To dismantle, operate in reverse order.

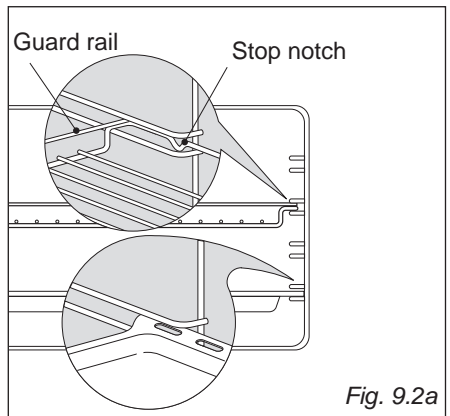

Fig. 9.2a

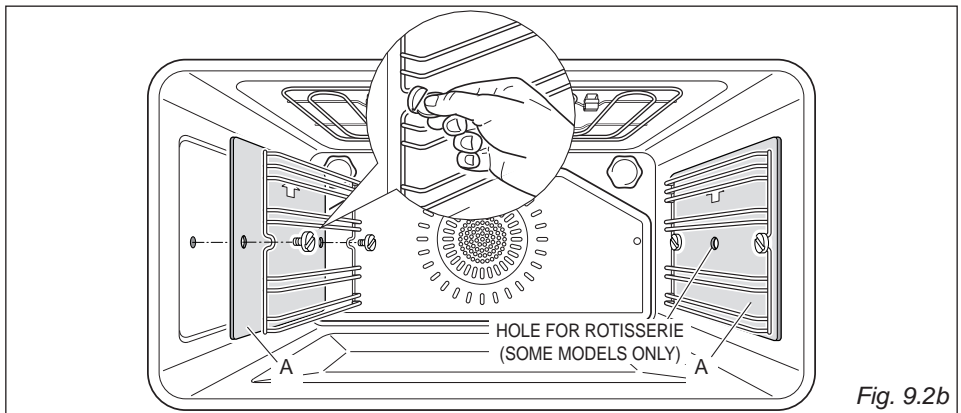

Fig. 9.2b

ADVICE FOR USE AND MAINTENANCE OF CATALYTIC PANELS (SUPPLIED WITH SOME MODELS ONLY)

The catalytic panels are covered with special microporous enamel which absorbs and does away with oil and fat splashes during normal baking over 200°C.

If, after cooking very fatty foods, the panels remain dirty, operate the oven "idling" on max temperature for about 30 minutes.

These panels do not require to be cleaned, however it is advised to periodically remove them from the oven (at least the side panels) and to wash them with tepid soapy water and then wipe off with a soft cloth.

DO NOT CLEAN OR WASH THEM WITH ABRASIVE PRODUCTS OR WITH PRODUCTS CONTAINING ACIDS OR ALKALIS.

The side panels are reversible and when the catalytic microporous enamel degrades, they can be turned to the other side.

GREASE FILTER (SUPPLIED WITH SOME MODELS ONLY)

A special screen is provided at the back of the oven to catch grease particles, mainly when meat is being roasted (fig. 9.3).

- When baking pastry etc. this filter should be removed.
- Slide in the grease filter on the back of the oven as in fig. 9.3.

Clean the filter after any cooking!

- The grease filter can be removed for cleaning and should be washed regularly in hot soapy water.
- Always clean the filter after cooking as any solid residues on it might adversely affect the oven performance.
- Always dry the filter properly before fitting it back into the oven.

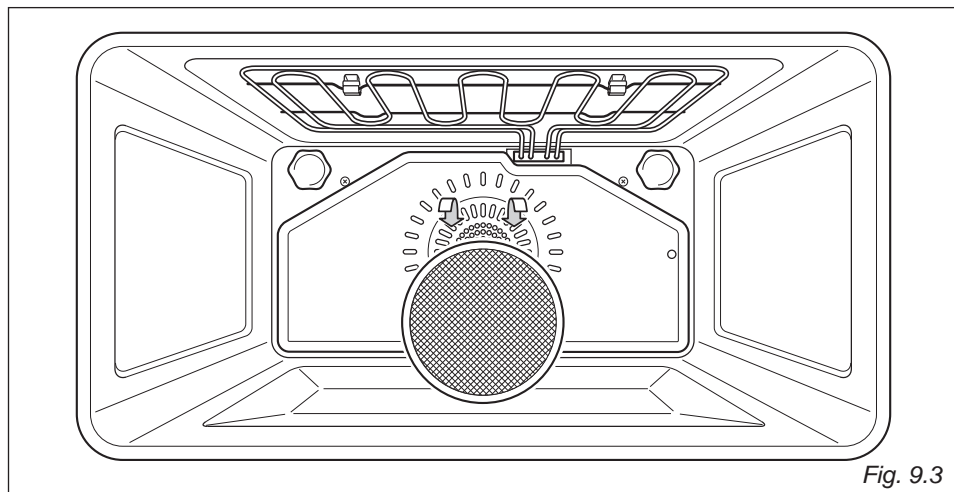

TILTING GRILL (SOME MODELS ONLY)

- The grill is secured to the rear wall of the oven on a hinge system that allows it to be lowered to allow proper access when cleaning the oven ceiling (fig. 9.4).
- To lower the grill element: use a flat-head screwdriver or a small coin to loosen the element fixing screws (fig. 9.5).
- When you have finished cleaning the oven ceiling, raise the grill element and screw the element fixing screws back onto the studs. Make sure that the fixing screws are tightened and the element is held securely in place.
- The grill element itself is self-cleaning.

Fig. 9.4

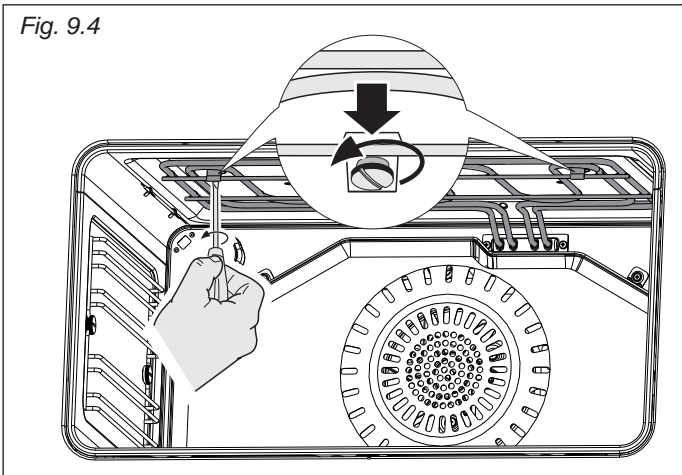
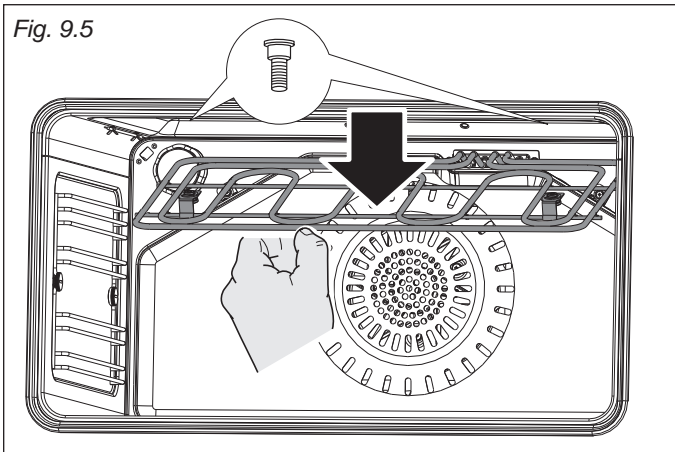

Fig. 9.5



REPLACING THE OVEN LAMPS

WARNING: Ensure the appliance is switched off before replacing the lamp to avoid the possibility of electric shock.

- Let the oven cavity and the heating elements to cool down;
- Switch off the electrical supply;
- Remove the protective cover "A" (fig. 9.6);
- Replace the halogen lamp "B" with a new one suitable for high temperatures (300°C) having the following specifications: 220-240 V, 50-60Hz and same power (check watt power as stamped in the lamp itself) of the replaced lamp;

IMPORTANT WARNING: Never replace the bulb with bare hands; contamination from your fingers can cause premature failure. Always use a clean cloth or gloves;

- Refit the protective cover "A";

Note: Oven bulb replacement is not covered by your guarantee.

The intended purpose of the lamps, fitted on this appliance, is to illuminate the oven cavity and thus help the user to better monitor the food while cooking. These lamps are not suitable for other usage (e.g. environments lighting).

This product contains more than one light source of energy efficiency class G.

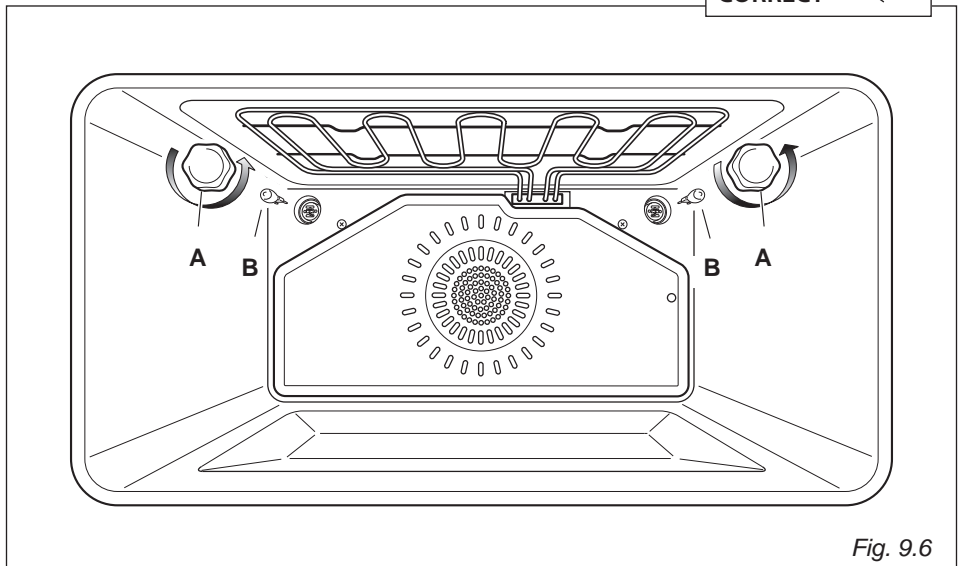
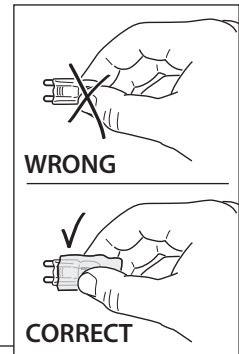

Fig. 9.6

TELESCOPIC SLIDING SHELF SUPPORTS (SOME MODELS ONLY)

The telescopic sliding shelf supports make it safer and easier to insert and remove the oven shelves and trays. They stop when they are pulled out to the maximum position.

Important! When fitting the sliding shelf supports, make sure that you fit:

- The slides to the top wire of a rack. They do not fit on the lower wire.
- The slides so that they run out towards the oven door.
- Both sides of each pair of shelf slides.
- Both sides on the same level.

To fix the sliding shelf supports onto the side racks:

- Screw the side racks onto the oven wall (interposing the catalytic panels if supplied) (fig. 9.2b).
- Fit the sliding shelf supports onto the top wire of a rack and press (fig. 9.7). You will hear a click as the safety locks clip over the wire.

IMPORTANT NOTE: when cooking with the rotisserie DO NOT position the grill support on the sliding shelf supports.

To remove the telescopic sliding shelf supports:

- Remove the side racks (and the catalytic liners if supplied) by unscrewing the fixing screws (fig. 9.2b).
- Lay down the telescopic sliding shelf support and side racks, with the telescopic sliding shelf support underneath.
- Find the safety locks. These are the tabs that clip over the wire of the side rack (arrow **1** in fig. 9.8).
- Pull the safety locks away from the wire to release the wire (arrow **2** in fig. 9.8).

Cleaning the sliding shelf supports:

- Wipe the supports with a damp cloth and a mild detergent only.
- Do not wash them in the dishwasher, immerse them in soapy water, or use oven cleaner on them.

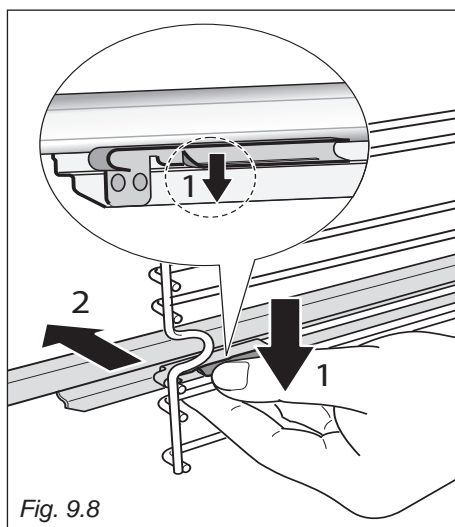
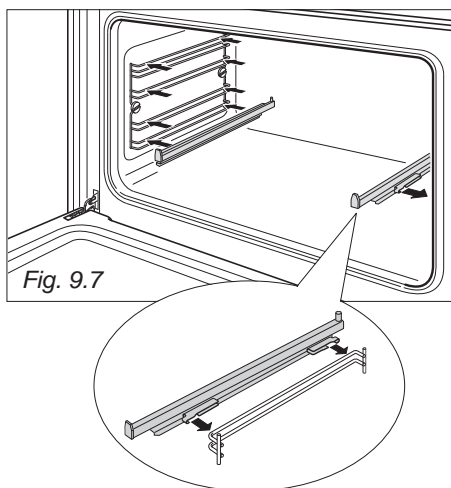

REMOVING AND REPLACING THE INNER DOOR GLASS PANE FOR CLEANING

If you wish to clean the inner glass of the door, make sure you follow the precautions and instructions very carefully.

Replacing the glass pane and the door incorrectly may result in damage to the appliance and may void your warranty.

IMPORTANT!

- Take care, the oven door is heavy. If you have any doubts, do not attempt to remove the door.
- Make sure the oven and all its parts have cooled down. Do not attempt to handle the parts of a hot oven.
- Take extreme care when handling the glass pane. Avoid the edges of the glass bumping against any surface. This may result in the glass shattering.
- **CAUTION:**
Do not use harsh abrasive cleaners or sharp metal scrapers to clean the oven door glass since they can scratch the surface, which may result in shattering of the glass.
- If you notice any sign of damage on any of the glass panes (such as chipping, or cracks), do not use the oven. Call your Authorised Service Centre or Customer Care.
- Make sure you replace the glass pane correctly. Do not use the oven without glass pane correctly in place.
- If the glass pane feels difficult to remove or replace, do not force it. Call your Authorised Repairer or Customer Care for help.

Note: service visits providing assistance with using or maintaining the oven are not covered by your warranty.

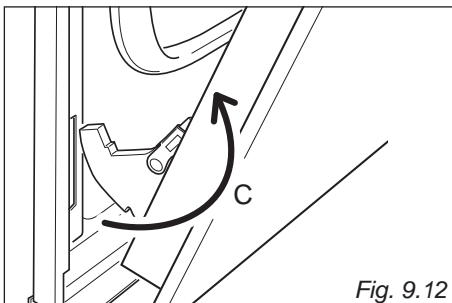
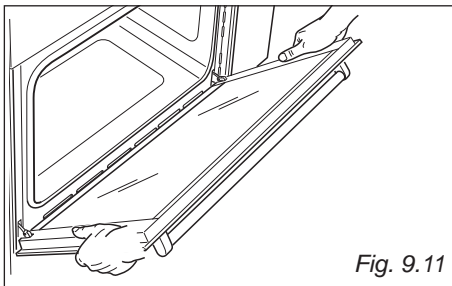
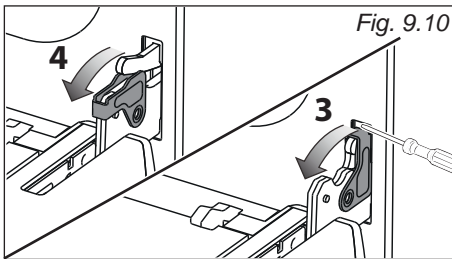
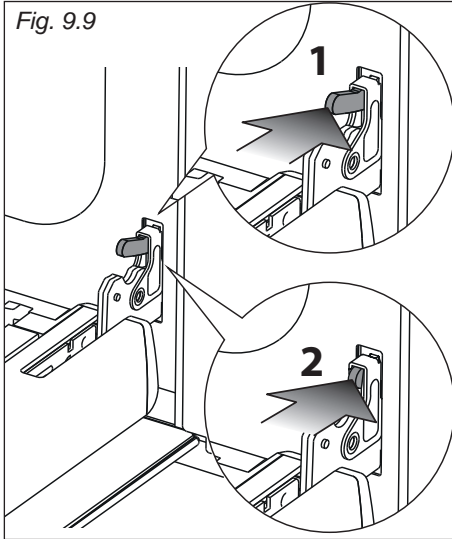

REMOVING THE OVEN DOOR

The oven door can easily be removed as follows:

- Open the door to the full extent (fig. 9.9) and check to see which side the damper hinge is fitted for the soft close feature as shown in fig. 9.9. This may be fitted on left or right of the door depending on exact model.
- Push the Damper Pin (arrow 1 in fig. 9.9) slowly, applying pressure until it moves in towards the oven and becomes flush with the hinge lever (arrow 2 in fig. 9.9). The Damper Pin does not react immediately and is very slow to move as it necessary to overcome the inertia of the soft close mechanism. If the Damper Pin is difficult to move, it may be necessary to use a suitable tool to allow extra pressure to be exerted, for example the back of a teaspoon. Please pay special care whilst pressing to avoid slipping and injury.
- Keeping the Damper Pin flush with the hinge lever (arrow 2 in fig. 9.9), rotate the hinge lever forward by using a small flat screw driver (arrow 3 in fig. 9.10) ensuring that you do not damage the enamel or oven.
- Rotate the hinge lever completely (arrow 4 in fig. 9.10). Repeat this step for the other hinge.
- Hold the oven door by two hands and close it until the hinge levers hook to the oven door and the door no longer closes easily. (fig. 9.11)
- Withdraw the hinge hooks from their location following arrow "C" (fig. 9.12).
- Rest the door on a soft surface.

Important!

Always keep a safe distance from the door hinges, paying special attention to the position of your hands.

If the door hinges are not correctly hooked, they could unhook and close suddenly and unexpectedly with risk of injury.



REMOVING THE INNER PANE OF GLASS

The oven door is fitted with no. 2 panes:

- no. 1 outside;
- no. 1 inner.

To clean all panes on both sides it is necessary to remove the inner pane as follows:

REMOVE THE INNER GLASS RETAINER

1. Remove the oven door and place it on a soft surface.
IMPORTANT: The door shall be placed horizontally as per fig. 9.13.
2. Press down on both tabs to release the glass retainer.
3. Remove the glass retainer.

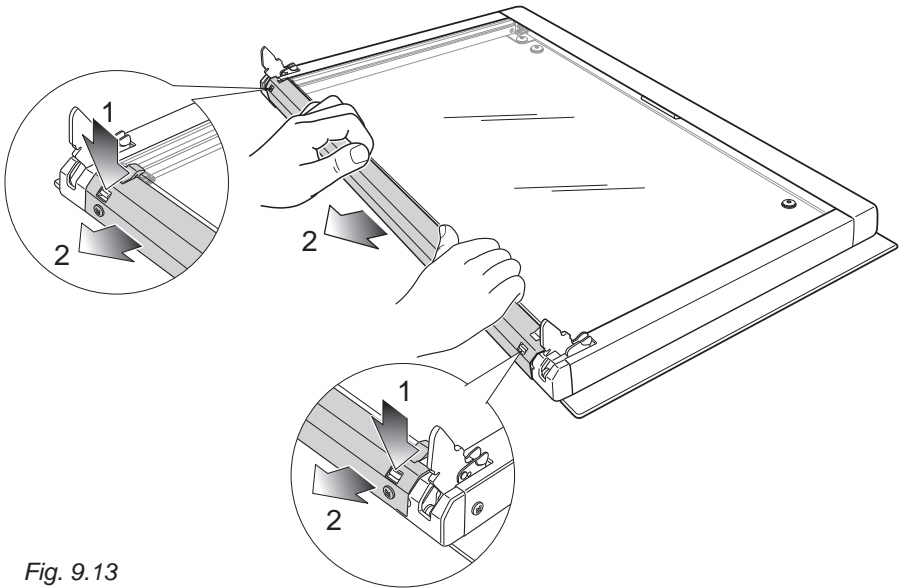

Fig. 9.13

REMOVE THE INNER GLASS PANE

Lift and remove the inner pane slightly, as shown in the figure 9.14.

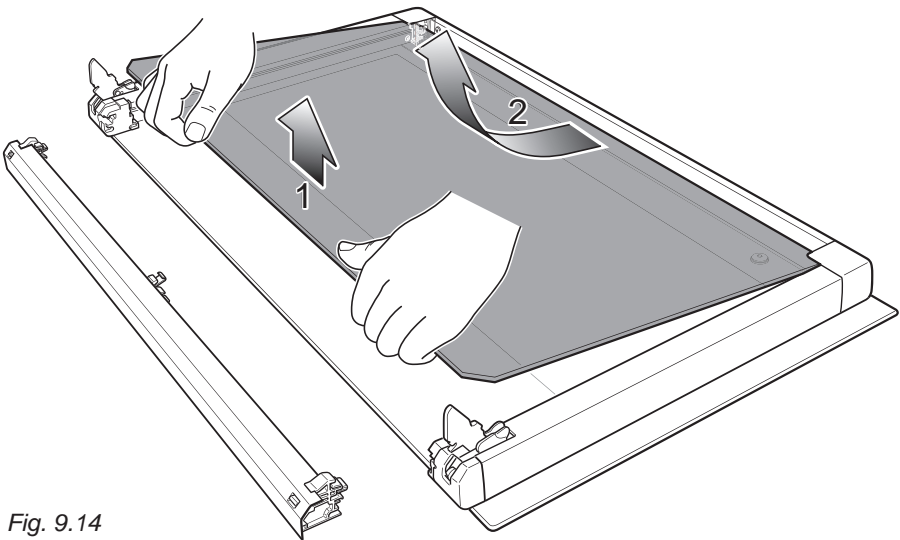

Fig. 9.14

AFTER CLEANING, REPLACE THE INNER GLASS PANE

When replacing the inner glass pane, make sure that:

- You replace the pane correctly, as shown. The pane must be in the position described below in order to fit into the door and to ensure that the appliance operates safely and correctly.
 - You take extra care not to bump the edges of the glass against any object or surface.
 - You do not force the pane into place. If you are experiencing difficulties replacing the pane, remove it and start the process again from the beginning. If this still does not help, call Customer Care.
 - Check that you are holding the pane the correct way. You should be able to read the wording on it as it faces you.
1. Insert the inner glass pane in the uppermost pair of grooves and push it slightly (arrow 1 in figure 9.15).
 2. Gently lower into place (arrow 2 in figure 9.15).

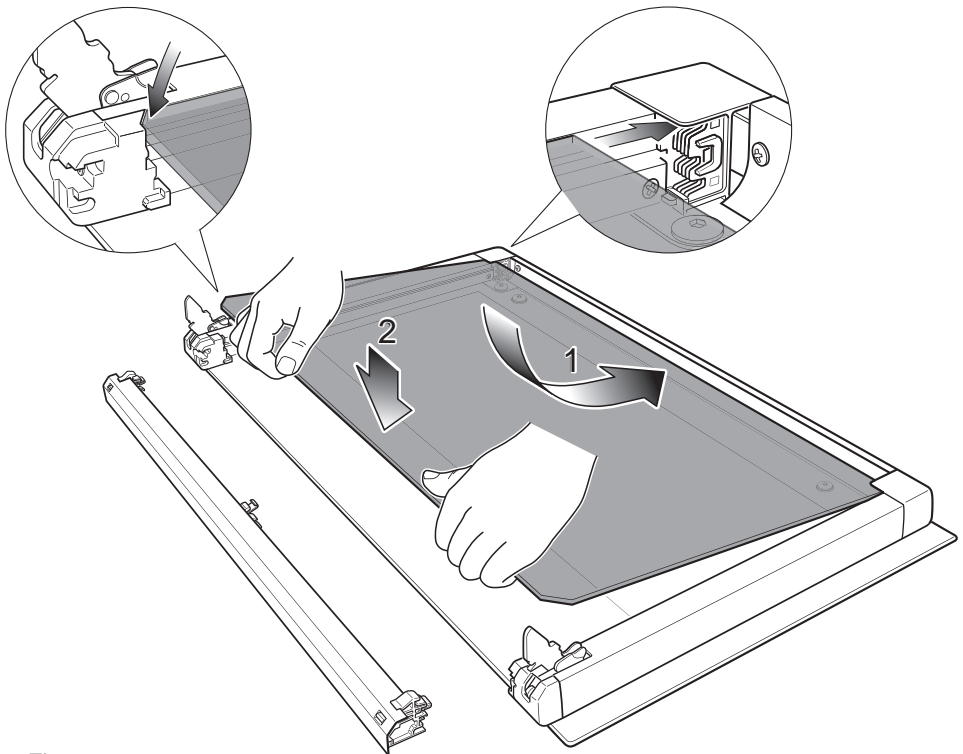

Fig. 9.15

REPLACE THE GLASS RETAINER

1. Position the glass retainer, as shown in the figure 9.16. It should sit on the bottom edge of the outer glass. Check that the clamps "M" are not deformed or damaged.
2. Gently push the glass retainer back into place. You should be able to hear the tabs on both sides click as they lock the glass retainer in.

Important !

Make sure the glass retainer is correctly and firmly in place and that the glass pane is secure.

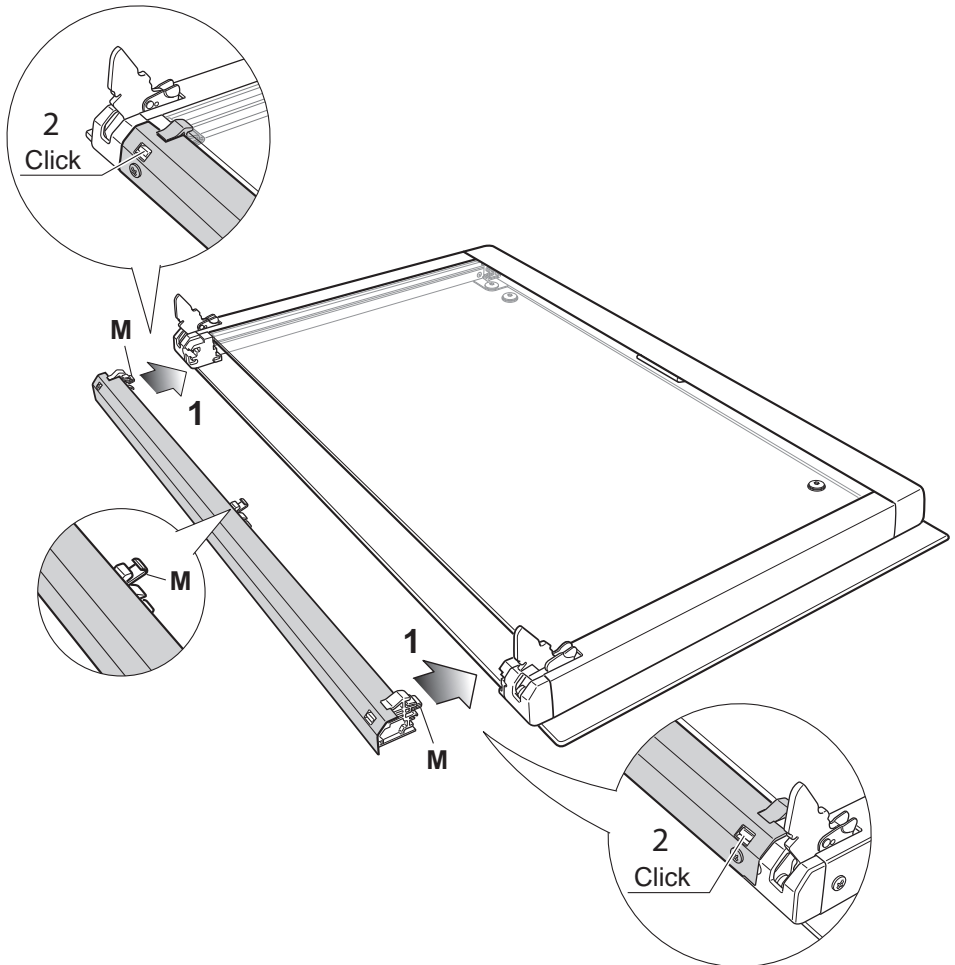
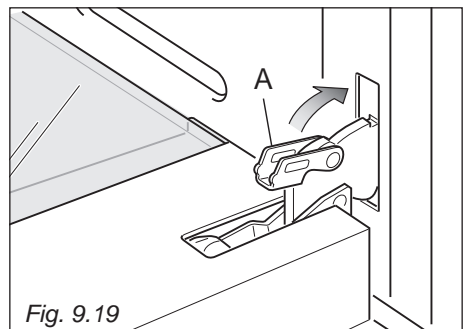
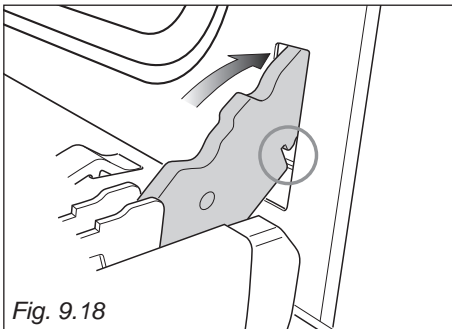
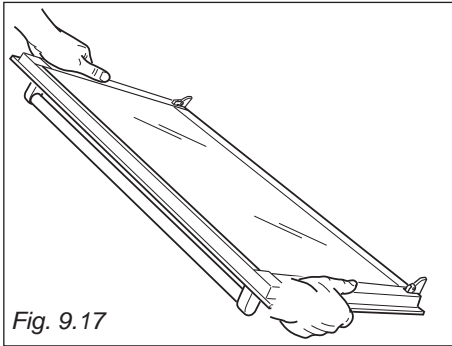

Fig. 9.16

REFIT THE DOOR

1. Hold the door firmly (fig. 9.17).
2. Insert the hinge tongues into the slots, making sure that the groove drops into place as shown in the figure 9.18.
3. Open the door to its full extent.
4. Fully close the levers "A" on the left and right hinges, as shown in the figure 9.19.
5. Close the door and check that it is properly in place.



The manufacturer cannot be held responsible for possible inaccuracies due to printing or transcription errors in the present booklet.

The manufacturer reserves the right to make all modifications to its products deemed necessary for manufacturer commercial reasons at any moment and without prior notice, without jeopardising the essential functional and safety characteristics of the appliances.

www.elba-cookers.com

ELBA

TALENT FOR COOKING

 Made in Italy 

Cod. 1106626 - B0